



ICSA SERRATURE fue fundada en 1978 como fabricante para los productores importantes de las cerraduras italiana. En 1982 la compañía comienza la venta directa de sus propios productos en los mercados. En 1997 ICSA ha abierto su nuevo edificio (6000 mq.) que incluye las operaciones completas. Esta nueva estructura se ha hecho para dar a los clientes un servicio siempre mejor y completo. Todas las operaciones se hacen dentro de la compañía con maquinaria nueva y moderna para alcanzar siempre un nivel más de calidad. Desde 2001 ha sido fundada ICSA Eurest, un sitio de la producción para los países europeos del este (en Hungría), que se convirtió en 2003 en ICSA Hungaria Kft. Durante 2006 se ha inaugurado la nueva sucursal, ICSA ESPAÑA S.L., que permitirá a ICSA Serrature iniciar su entrada en el mercado europeo.

Desde Enero 2026 ICSA ESPAÑA , pasa a la distribución en el canal Nacional bajo la SEBALCAB S.L. teniendo presencia en la mayoría del territorio nacional , gracias a su red de Agentes Comerciales los cuales podran ayudar y dar solución a cada cliente .

SEBALCAB S.L.





CILINDROS

info@sebalcab.es

GAMA DE CILINDROS



		C4	C5	C6	S2	S3	S5	S6	S7	S8	S10
TIPO DE LLAVE	Vertical Rersibile	X	X	X	X	X					
	Horizontal Reversible						X	X	X	X	X
	Comp. avec rosaces							X	X	X	X
SEGURIDAD ACTIVA	Tarjeta de Propiedad							Opcional	X	X	X
	Combinaciones	30.000	30.000	100.000	30.000	100.000	30.000	30.000	1.600.000	1.600.000	1.600.000
SEGURIDAD PASIVA	Taladro				X	X			X	X	X
	Rotura				X	X				X	X
	Guanzua				X	X	X	X	X	X	X
CONTROL DE ACCESOS	K.A.	X	X	X	X	X	X	X	X	X	X
	M.K.		X	X	X	X	X	X	X	X	X
	G.M.K.			X	X	X	X	X	X	X	X
	G.G.M.K.			X	X	X	X	X	X	X	X
	Llave de Obra						X	X	X	X	X
GAMA		X	X	X	X	X	X	X	X	X	X
			X	X	X	X	X	X	X	X	X
		X	X	X	X	X	X	X	X	X	X
			X	X	X	X	X	X	X	X	X
			X	X	X	X	X	X	X	X	X



MOD S10 ART. HS10



CARACTERÍSTICAS TÉCNICAS: • Resistente al BUMPING y al

- PICKING
- Sistema de cifrado 10 pernos (6 activos, 4 pasivos)
- Cuerpo de latón con dos láminas en toda la longitud del cilindro
- Rotores de latón • Leva de fricción en acero sinterizado autolubrificante
- De primera y tercera posición pernos de acero cementado
- Pernos de latón niquelado

- En primera y tercera posición contrapernos de acero cementado
- Contrapernos de latón niquelado • Contrapernos especiales ANTI BUMPING • Muelles de acero inoxidable
- Leva DIN o leva CORTA desplazada de acero sinterizado

LLAVES PLANAS REVERSIBLES: • Del aleación especial de latón,

- niqueladas
- Con numeración de código en la cabeza de la llave

RESISTENCIA A LA PERFORACIÓN: • Perno de acero templado en

- ambos lados del cuerpo del cilindro
- Contraperno de acero templado en primera posición
- Contrapernos de forma especial
- NORMAS:** • Conforme a la norma EN 1303:05 • Resistencia al ataque: Grado 1 • Seguridad llave: grado 6 • Durabilidad: grado 6 • 1.600.000 combinaciones

DOTACIÓN: • 5 llaves y 5 cabezas en

- plástico
- Tarjeta de código • Tornillo de fijación 5Max50 ACABADOS: • Latón • Níquel Satinado

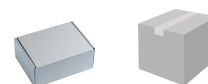

LEVA LARGA 15mm.

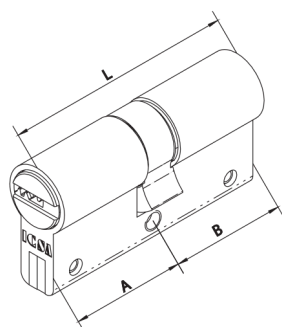

L mm	A mm	B mm	COD. LATON	COD. NIQUEL		
60	30	30	1150303013-	1150303043-	1	20
65	30	35	1150303513-	1150303543-	1	20
70	30	40	1150304013-	1150304043-	1	20
70	35	35	1150353513-	1150353543-	1	20
75	30	45	1150304513-	1150304543-	1	20
75	35	40	1150354013-	1150354043-	1	20
80	30	50	1150305013-	1150305043-	1	20
80	35	45	1150354513-	1150354543-	1	20
80	40	40	1150404013-	1150404043-	1	20
85	30	55	1150305513-	1150305543-	1	20
85	35	50	1150355013-	1150355043-	1	20
85	40	45	1150404513-	1150404543-	1	20
90	30	60	1150306013-	1150306043-	1	20
90	35	55	1150355513-	1150355543-	1	20
90	40	50	1150405013-	1150405043-	1	20
90	45	45	1150454513-	1150454543-	1	20
95	30	65	1150306513-	1150306543-	1	20
95	35	60	1150356013-	1150356043-	1	20
95	40	55	1150405513-	1150405543-	1	20
95	45	50	1150455013-	1150455043-	1	20
100	30	70	1150307013-	1150307043-	1	20
100	35	65	1150356513-	1150356543-	1	20
100	40	60	1150406013-	1150406043-	1	20
100	45	55	1150455513-	1150455543-	1	20
100	50	50	1150505013-	1150505043-	1	20
105	30	75	1150307513-	1150307543-	1	20
105	35	70	1150357013-	1150357043-	1	20
105	50	55	1150505513-	1150505543-	1	20
110	30	80	1150308013-	1150308043-	1	20
110	40	70	1150407013-	1150407043-	1	20
110	50	60	1150506013-	1150506043-	1	20
110	55	55	1150555513-	1150555543-	1	20
115	30	85	1150308513-	1150308543-	1	20
115	40	75	1150407513-	1150407543-	1	20
115	50	65	1150506513-	1150506543-	1	20

LEVA CORTA 13mm.

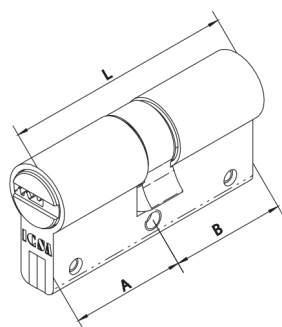

60	30	30	1150303012-	1150303042-	1	20
65	30	35	1150303512-	1150303542-	1	20
70	30	40	1150304012-	1150304042-	1	20
70	35	35	1150353512-	1150353542-	1	20
75	30	45	1150304512-	1150304542-	1	20
75	35	40	1150354012-	1150354042-	1	20
80	30	50	1150305012-	1150305042-	1	20
80	35	45	1150354512-	1150354542-	1	20
80	40	40	1150404012-	1150404042-	1	20
85	30	55	1150305512-	1150305542-	1	20
85	35	50	1150355012-	1150355042-	1	20
85	40	45	1150404512-	1150404542-	1	20
90	30	60	1150306012-	1150306042-	1	20
90	35	55	1150355512-	1150355542-	1	20
90	40	50	1150405012-	1150405042-	1	20
90	45	45	1150454512-	1150454542-	1	20
95	30	65	1150306512-	1150306542-	1	20
95	35	60	1150356012-	1150356042-	1	20
95	40	55	1150405512-	1150405542-	1	20
95	45	50	1150455012-	1150455042-	1	20
100	30	70	1150307012-	1150307042-	1	20
100	35	65	1150356512-	1150356542-	1	20
100	40	60	1150406012-	1150406042-	1	20
100	45	55	1150455512-	1150455542-	1	20
100	50	50	1150505012-	1150505042-	1	20
105	30	75	1150307512-	1150307542-	1	20
105	35	70	1150357012-	1150357042-	1	20
105	50	55	1150505512-	1150505542-	1	20
110	30	80	1150308012-	1150308042-	1	20
110	40	70	1150407012-	1150407042-	1	20
110	50	60	1150506012-	1150506042-	1	20
110	55	55	1150555512-	1150555542-	1	20
115	30	85	1150308512-	1150308542-	1	20
115	40	75	1150407512-	1150407542-	1	20
115	50	65	1150506512-	1150506542-	1	20

Otras medidas bajo pedido

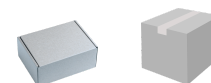

LEVA LARGA 15mm.

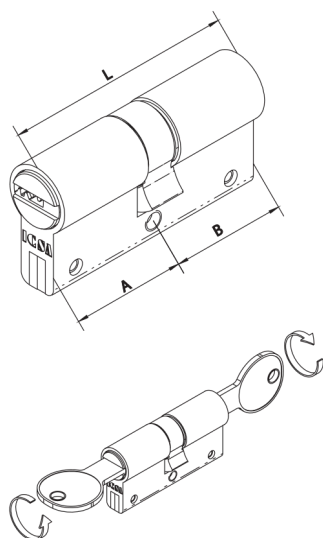

L mm	A mm	B mm	COD. LATON	COD. NIQUEL	1	20
60	30	30	1151303013-	1151303043-	1	20
65	30	35	1151303513-	1151303543-	1	20
70	30	40	1151304013-	1151304043-	1	20
70	35	35	1151353513-	1151353543-	1	20
75	30	45	1151304513-	1151304543-	1	20
75	35	40	1151354013-	1151354043-	1	20
80	30	50	1151305013-	1151305043-	1	20
80	35	45	1151354513-	1151354543-	1	20
80	40	40	1151404013-	1151404043-	1	20
85	30	55	1151305513-	1151305543-	1	20
85	35	50	1151355013-	1151355043-	1	20
85	40	45	1151404513-	1151404543-	1	20
90	30	60	1151306013-	1151306043-	1	20
90	35	55	1151355513-	1151355543-	1	20
90	40	50	1151405013-	1151405043-	1	20
90	45	45	1151454513-	1151454543-	1	20
95	30	65	1151306513-	1151306543-	1	20
95	35	60	1151356013-	1151356043-	1	20
95	40	55	1151405513-	1151405543-	1	20
95	45	50	1151455013-	1151455043-	1	20
100	30	70	1151307013-	1151307043-	1	20
100	35	65	1151356513-	1151356543-	1	20
100	40	60	1151406013-	1151406043-	1	20
100	45	55	1151455513-	1151455543-	1	20
100	50	50	1151505013-	1151505043-	1	20
105	30	75	1151307513-	1151307543-	1	20
105	35	70	1151357013-	1151357043-	1	20
105	50	55	1151505513-	1151505543-	1	20
110	30	80	1151308013-	1151308043-	1	20
110	40	70	1151407013-	1151407043-	1	20
110	50	60	1151506013-	1151506043-	1	20
110	55	55	1151555513-	1151555543-	1	20
115	30	85	1151308513-	1151308543-	1	20
115	40	75	1151407513-	1151407543-	1	20
115	50	65	1151506513-	1151506543-	1	20

LEVA CORTA 13mm.

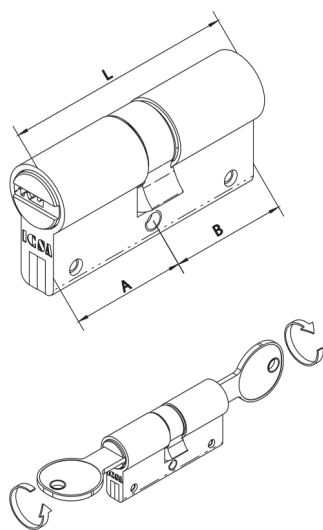

60	30	30	1151303012-	1151303042-	1	20
65	30	35	1151303512-	1151303542-	1	20
70	30	40	1151304012-	1151304042-	1	20
70	35	35	1151353512-	1151353542-	1	20
75	30	45	1151304512-	1151304542-	1	20
75	35	40	1151354012-	1151354042-	1	20
80	30	50	1151305012-	1151305042-	1	20
80	35	45	1151354512-	1151354542-	1	20
80	40	40	1151404012-	1151404042-	1	20
85	30	55	1151305512-	1151305542-	1	20
85	35	50	1151355012-	1151355042-	1	20
85	40	45	1151404512-	1151404542-	1	20
90	30	60	1151306012-	1151306042-	1	20
90	35	55	1151355512-	1151355542-	1	20
90	40	50	1151405012-	1151405042-	1	20
90	45	45	1151454512-	1151454542-	1	20
95	30	65	1151306512-	1151306542-	1	20
95	35	60	1151356012-	1151356042-	1	20
95	40	55	1151405512-	1151405542-	1	20
95	45	50	1151455012-	1151455042-	1	20
100	30	70	1151307012-	1151307042-	1	20
100	35	65	1151356512-	1151356542-	1	20
100	40	60	1151406012-	1151406042-	1	20
100	45	55	1151455512-	1151455542-	1	20
100	50	50	1151505012-	1151505042-	1	20
105	30	75	1151307512-	1151307542-	1	20
105	35	70	1151357012-	1151357042-	1	20
105	50	55	1151505512-	1151505542-	1	20
110	30	80	1151308012-	1151308042-	1	20
110	40	70	1151407012-	1151407042-	1	20
110	50	60	1151506012-	1151506042-	1	20
110	55	55	1151555512-	1151555542-	1	20
115	30	85	1151308512-	1151308542-	1	20
115	40	75	1151407512-	1151407542-	1	20
115	50	65	1151506512-	1151506542-	1	20

Otras medidas bajo pedido

MOD S10 ART. HS10 168Z

DOBLE CILINDRO CON POMO

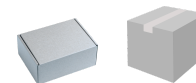

LEVA LARGA 15mm.

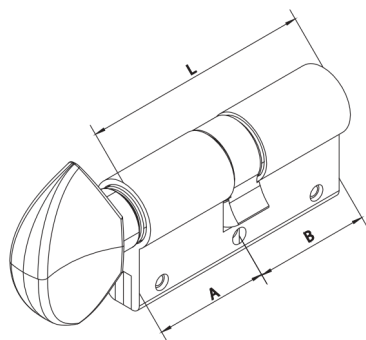

POMO EN ZAMAK

LEVA CORTA 13mm.

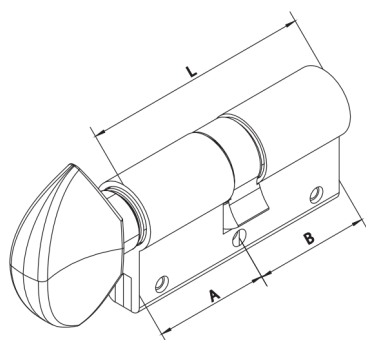

POMO ZAMAK

L mm	A mm	B mm	COD. LATON	COD. NIQUEL		
60	30	30	1167303013-	1167303043-	1	20
65	30	35	1167303513-	1167303543-	1	20
65	35	30	1167353013-	1167353043-	1	20
70	30	40	1167304013-	1167304043-	1	20
70	35	35	1167353513-	1167353543-	1	20
70	40	30	1167403013-	1167403043-	1	20
75	30	45	1167304513-	1167304543-	1	20
75	35	40	1167354013-	1167354043-	1	20
75	40	35	1167403513-	1167403543-	1	20
75	45	30	1167453013-	1167453043-	1	20
80	30	50	1167305013-	1167305043-	1	20
80	35	45	1167354513-	1167354543-	1	20
80	40	40	1167404013-	1167404043-	1	20
80	45	35	1167453513-	1167453543-	1	20
80	50	30	1167503013-	1167503043-	1	20
85	30	55	1167305513-	1167305543-	1	20
85	35	50	1167355013-	1167355043-	1	20
85	40	45	1167404513-	1167404543-	1	20
85	45	40	1167454013-	1167454043-	1	20
85	50	35	1167503513-	1167503543-	1	20
85	55	30	1167553013-	1167553043-	1	20
90	30	60	1167306013-	1167306043-	1	20
90	35	55	1167355513-	1167355543-	1	20
90	40	50	1167405013-	1167405043-	1	20
90	45	45	1167454513-	1167454543-	1	20
90	50	40	1167504013-	1167504043-	1	20
90	55	35	1167553513-	1167553543-	1	20
90	60	30	1167603013-	1167603043-	1	20
95	30	65	1167306513-	1167306543-	1	20
95	35	60	1167356013-	1167356043-	1	20
95	40	55	1167405513-	1167405543-	1	20
95	45	50	1167455013-	1167455043-	1	20
95	50	45	1167504513-	1167504543-	1	20
95	55	40	1167554013-	1167554043-	1	20
95	60	35	1167603513-	1167603543-	1	20
95	65	30	1167653013-	1167653043-	1	20
100	30	70	1167307013-	1167307043-	1	20
100	35	65	1167356513-	1167356543-	1	20
100	40	60	1167406013-	1167406043-	1	20
100	45	55	1167455513-	1167455543-	1	20
100	50	50	1167505013-	1167505043-	1	20
100	55	45	1167554513-	1167554543-	1	20
100	60	40	1167604013-	1167604043-	1	20
100	65	35	1167653513-	1167653543-	1	20
100	70	30	1167703013-	1167703043-	1	20
60	30	30	1167303012-	1167303042-	1	20
65	30	35	1167303512-	1167303542-	1	20
65	35	30	1167353012-	1167353042-	1	20
70	30	40	1167304012-	1167304042-	1	20
70	35	35	1167353512-	1167353542-	1	20
70	40	30	1167403012-	1167403042-	1	20
75	30	45	1167304512-	1167304542-	1	20
75	35	40	1167354012-	1167354042-	1	20
75	40	35	1167403512-	1167403542-	1	20
75	45	30	1167453012-	1167453042-	1	20
80	30	50	1167305012-	1167305042-	1	20
80	35	45	1167354512-	1167354542-	1	20
80	40	40	1167404012-	1167404042-	1	20
80	45	35	1167453512-	1167453542-	1	20
80	50	30	1167503012-	1167503042-	1	20
85	30	55	1167305512-	1167305542-	1	20
85	35	50	1167355012-	1167355042-	1	20
85	40	45	1167404512-	1167404542-	1	20
85	45	40	1167454012-	1167454042-	1	20
85	50	35	1167503512-	1167503542-	1	20
85	55	30	1167553012-	1167553042-	1	20
90	30	60	1167306012-	1167306042-	1	20
90	35	55	1167355512-	1167355542-	1	20
90	40	50	1167405012-	1167405042-	1	20
90	45	45	1167454512-	1167454542-	1	20
90	50	40	1167504012-	1167504042-	1	20
90	55	35	1167553512-	1167553542-	1	20
90	60	30	1167603012-	1167603042-	1	20
95	30	65	1167306512-	1167306542-	1	20
95	35	60	1167356012-	1167356042-	1	20
95	40	55	1167405512-	1167405542-	1	20
95	45	50	1167455012-	1167455042-	1	20
95	50	45	1167504512-	1167504542-	1	20
95	55	40	1167554012-	1167554042-	1	20
95	60	35	1167603512-	1167603542-	1	20
95	65	30	1167653012-	1167653042-	1	20
100	30	70	1167307012-	1167307042-	1	20
100	35	65	1167356512-	1167356542-	1	20
100	40	60	1167406012-	1167406042-	1	20
100	45	55	1167455512-	1167455542-	1	20
100	50	50	1167505012-	1167505042-	1	20
100	55	45	1167554512-	1167554542-	1	20
100	60	40	1167604012-	1167604042-	1	20
100	65	35	1167653512-	1167653542-	1	20
100	70	30	1167703012-	1167703042-	1	20

Otras medidas bajo pedido



MOD S6 ART. HS6 PRO



ES

CARACTERÍSTICAS TÉCNICAS:

- Cuerpo de latón con rotura controlada
- 6 Pernos totales, dos de ellos de acero inoxidable ANTI TALADRO
- 4 Contrapernos en latón y 2 en acero Inoxidable: 2 ANTI PICKING y 2 ANTI BUMPING
- Pernos de acero templado ANTI TALADRO en el cuerpo
- Rotores en latón
- Muelles de acero inoxidable
- Leva Larga DIN 30° de acero sinterizado autolubricante

LLAVES PLANAS

REVERSIBLES:

- Específicas en latón niquelado
- Llave larga compatible con escudo
- Con numeración de código en la cabeza de la llave

NORMAS:

- Conforme a la norma EN 1303:2005
- Durabilidad : grado 5
- 30.000 cifrados

DOTACIÓN:

- 5 llaves en bolsa de nylon negra termosellada
- Tornillo 5Ma x 72mm.
- Tarjeta de propiedad en bolsa de nylon negro termosellada

OPCIONAL:

- 5 Cabeza de plástico negro para las llaves

ACABADOS:

- Latón
- Latón niquelado satinado
- Acabados especiales bajo pedido

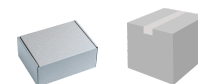

LEVA LARGA 15mm.

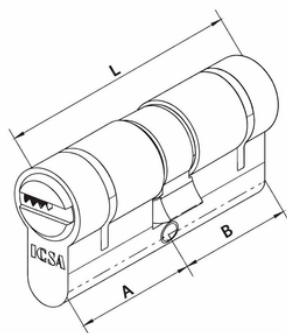

L mm	A mm	B mm	COD. LATON	COD. NIQUEL		
60	30	30	H151303013-	H151303043-	1	20
65	30	35	H151303513-	H151303543-	1	20
70	30	40	H151304013-	H151304043-	1	20
70	35	35	H151353513-	H151353543-	1	20
75	30	45	H151304513-	H151304543-	1	20
75	35	40	H151354013-	H151354043-	1	20
80	30	50	H151305013-	H151305043-	1	20
80	35	45	H151354513-	H151354543-	1	20
80	40	40	H151404013-	H151404013-	1	20
85	30	55	H151305513-	H151305543-	1	20
85	35	50	H151355013-	H151355043-	1	20
85	40	45	H151404513-	H151404543-	1	20
90	30	60	H151306013-	H151306043-	1	20
90	35	55	H151355513-	H151355543-	1	20
90	40	50	H151405013-	H151405043-	1	20
90	45	45	H151454513-	H151454543-	1	20
95	30	65	H151306513-	H151306543-	1	20
95	35	60	H151356013-	H151356043-	1	20
95	40	55	H151405513-	H151405543-	1	20
95	45	50	H151455013-	H151455043-	1	20
100	30	70	H151307013-	H151307043-	1	20
100	35	65	H151356513-	H151356543-	1	20
100	40	60	H151406013-	H151406043-	1	20
100	45	55	H151455513-	H151455543-	1	20
100	50	50	H151505013-	H151505043-	1	20
105	30	75	H151307513-	H151307543-	1	20
105	35	70	H151357013-	H151357043-	1	20
105	50	55	H151505513-	H151505543-	1	20
110	30	80	H151308013-	H151308043-	1	20
110	40	70	H151407013-	H151407043-	1	20
110	50	60	H151506013-	H151506043-	1	20
110	55	55	H151555513-	H151555543-	1	20
115	30	85	H151308513-	H151308543-	1	20
115	40	75	H151407513-	H151407543-	1	20
115	50	65	H151506513-	H151506543-	1	20
120	50	70	H151507013-	H151507043-	1	20
120	55	65	H151556513-	H151556543-	1	20
120	60	60	H151606013-	H151606043-	1	20

LEVA CORTA 13mm.

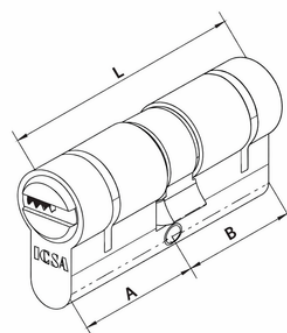

60	30	30	H151303012-	H151303042-	1	20
65	30	35	H151303512-	H151303542-	1	20
70	30	40	H151304012-	H151304042-	1	20
70	35	35	H151353512-	H151353542-	1	20
75	30	45	H151304512-	H151304542-	1	20
75	35	40	H151354012-	H151354042-	1	20
80	30	50	H151305012-	H151305042-	1	20
80	35	45	H151354512-	H151354542-	1	20
80	40	40	H151404012-	H151404042-	1	20
85	30	55	H151305512-	H151305542-	1	20
85	35	50	H151355012-	H151355042-	1	20
85	40	45	H151404512-	H151404542-	1	20
90	30	60	H151306012-	H151306042-	1	20
90	35	55	H151355512-	H151355542-	1	20
90	40	50	H151405012-	H151405042-	1	20
90	45	45	H151454512-	H151454542-	1	20
95	30	65	H151306512-	H151306542-	1	20
95	35	60	H151356012-	H151356042-	1	20
95	40	55	H151405512-	H151405542-	1	20
95	45	50	H151455012-	H151455042-	1	20
100	30	70	H151307012-	H151307042-	1	20
100	35	65	H151356512-	H151356542-	1	20
100	40	60	H151406012-	H151406042-	1	20
100	45	55	H151455512-	H151455542-	1	20
100	50	50	H151505012-	H151505042-	1	20
105	30	75	H151307512-	H151307542-	1	20
105	35	70	H151357012-	H151357042-	1	20
105	50	55	H151505512-	H151505542-	1	20
110	30	80	H151308012-	H151308042-	1	20
110	40	70	H151407012-	H151407042-	1	20
110	50	60	H151506012-	H151506042-	1	20
110	55	55	H151555512-	H151555542-	1	20
115	30	85	H151308512-	H151308542-	1	20
115	40	75	H151407512-	H151407542-	1	20
115	50	65	H151506512-	H151506542-	1	20
120	50	70	H151507012-	H151507042-	1	20
120	55	65	H151556512-	H151556542-	1	20
120	60	60	H151606012-	H151606042-	1	20

Otras medidas bajo pedido

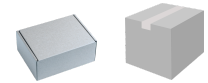

LEVA LARGA 15mm.

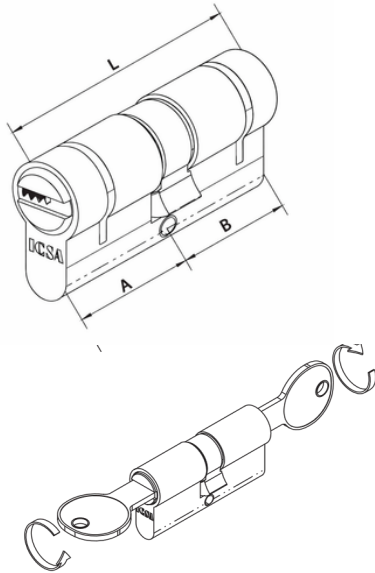

L mm	A mm	B mm	COD. LATON	COD. NIQUEL		
60	30	30	H152303013-	H152303043-	1	20
65	30	35	H152303513-	H152303543-	1	20
70	30	40	H152304013-	H152304043-	1	20
70	35	35	H152353513-	H152353543-	1	20
75	30	45	H152304513-	H152304543-	1	20
75	35	40	H152354013-	H152354043-	1	20
80	30	50	H152305013-	H152305043-	1	20
80	35	45	H152354513-	H152354543-	1	20
80	40	40	H152404013-	H152404043-	1	20
85	30	55	H152305513-	H152305543-	1	20
85	35	50	H152355013-	H152355043-	1	20
85	40	45	H152404513-	H152404543-	1	20
90	30	60	H152306013-	H152306043-	1	20
90	35	55	H152355513-	H152355543-	1	20
90	40	50	H152405013-	H152405043-	1	20
90	45	45	H152454513-	H152454543-	1	20
95	30	65	H152306513-	H152306543-	1	20
95	35	60	H152356013-	H152356043-	1	20
95	40	55	H152405513-	H152405543-	1	20
95	45	50	H152455013-	H152455043-	1	20
100	30	70	H152307013-	H152307043-	1	20
100	35	65	H152356513-	H152356543-	1	20
100	40	60	H152406013-	H152406043-	1	20
100	45	55	H152455513-	H152455543-	1	20
100	50	50	H152505013-	H152505043-	1	20
105	30	75	H152307513-	H152307543-	1	20
105	35	70	H152357013-	H152357043-	1	20
105	50	55	H152505513-	H152505543-	1	20
110	30	80	H152308013-	H152308043-	1	20
110	40	70	H152407013-	H152407043-	1	20
110	50	60	H152506013-	H152506043-	1	20
110	55	55	H152555513-	H152555543-	1	20
115	30	85	H152308513-	H152308543-	1	20
115	40	75	H152407513-	H152407543-	1	20
115	50	65	H152506513-	H152506543-	1	20

LEVA CORTA 13mm.

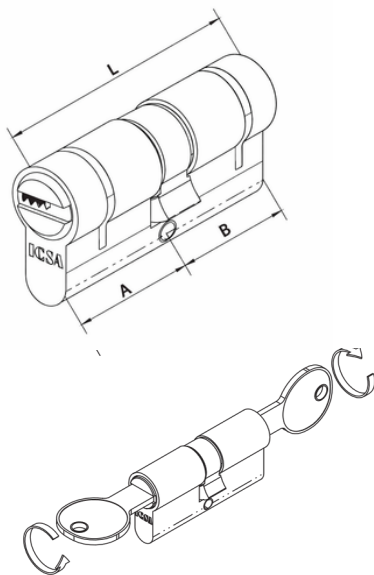

60	30	30	H152303012-	H152303042-	1	20
65	30	35	H152303512-	H152303542-	1	20
70	30	40	H152304012-	H152304042-	1	20
70	35	35	H152353512-	H152353542-	1	20
75	30	45	H152304512-	H152304542-	1	20
75	35	40	H152354012-	H152354042-	1	20
80	30	50	H152305012-	H152305042-	1	20
80	35	45	H152354512-	H152354542-	1	20
80	40	40	H152404012-	H152404042-	1	20
85	30	55	H152305512-	H152305542-	1	20
85	35	50	H152355012-	H152355042-	1	20
85	40	45	H152404512-	H152404542-	1	20
90	30	60	H152306012-	H152306042-	1	20
90	35	55	H152355512-	H152355542-	1	20
90	40	50	H152405012-	H152405042-	1	20
90	45	45	H152454512-	H152454542-	1	20
95	30	65	H152306512-	H152306542-	1	20
95	35	60	H152356012-	H152356042-	1	20
95	40	55	H152405512-	H152405542-	1	20
95	45	50	H152455012-	H152455042-	1	20
100	30	70	H152307012-	H152307042-	1	20
100	35	65	H152356512-	H152356542-	1	20
100	40	60	H152406012-	H152406042-	1	20
100	45	55	H152455512-	H152455542-	1	20
100	50	50	H152505012-	H152505042-	1	20
105	30	75	H152307512-	H152307542-	1	20
105	35	70	H152357012-	H152357042-	1	20
105	50	55	H152505512-	H152505542-	1	20
110	30	80	H152308012-	H152308042-	1	20
110	40	70	H152407012-	H152407042-	1	20
110	50	60	H152506012-	H152506042-	1	20
110	55	55	H152555512-	H152555542-	1	20
115	30	85	H152308512-	H152308542-	1	20
115	40	75	H152407512-	H152407542-	1	20
115	50	65	H152506512-	H152506542-	1	20

Otras medidas consultar

MOD S6 ART. HS6 PRO 168Z

DOBLE POMO CON POMO

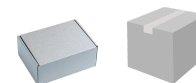

LEVA LARGA 15mm.

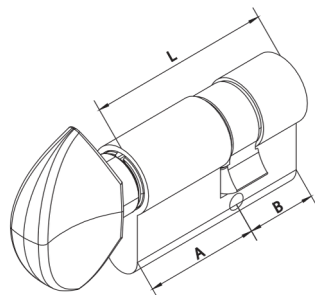

POMO EN ZAMAK

LEVA CORTA 13mm.

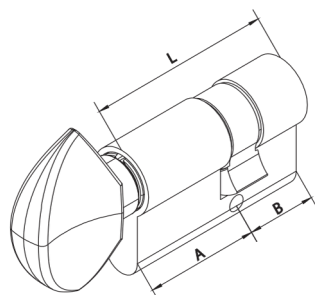

POMO ZAMAK

L mm	A mm	B mm	COD. LATON	COD. NIQUEL		
60	30	30	H165303013-	H165303043-	1	20
65	30	35	H165303513-	H165303543-	1	20
65	35	30	H165353013-	H165353043-	1	20
70	30	40	H165304013-	H165304043-	1	20
70	35	35	H165353513-	H165353543-	1	20
70	40	30	H165403013-	H165403043-	1	20
75	30	45	H165304513-	H165304543-	1	20
75	35	40	H165354013-	H165354043-	1	20
75	40	35	H165403513-	H165403543-	1	20
75	45	30	H165453013-	H165453043-	1	20
80	30	50	H165305013-	H165305043-	1	20
80	35	45	H165354513-	H165354543-	1	20
80	40	40	H165404013-	H165404043-	1	20
80	45	35	H165453513-	H165453543-	1	20
80	50	30	H165503013-	H165503043-	1	20
85	30	55	H165305513-	H165305543-	1	20
85	35	50	H165355013-	H165355043-	1	20
85	40	45	H165404513-	H165404543-	1	20
85	45	40	H165454013-	H165454043-	1	20
85	50	35	H165503513-	H165503543-	1	20
85	55	30	H165553013-	H165553043-	1	20
90	30	60	H165306013-	H165306043-	1	20
90	35	55	H165355513-	H165355543-	1	20
90	40	50	H165405013-	H165405043-	1	20
90	45	45	H165454513-	H165454543-	1	20
90	50	40	H165504013-	H165504043-	1	20
90	55	35	H165553513-	H165553543-	1	20
90	60	30	H165603013-	H165603043-	1	20
95	30	65	H165306513-	H165306543-	1	20
95	35	60	H165356013-	H165356043-	1	20
95	40	55	H165405513-	H165405543-	1	20
95	45	50	H165455013-	H165455043-	1	20
95	50	45	H165504513-	H165504543-	1	20
95	55	40	H165554013-	H165554043-	1	20
95	60	35	H165603513-	H165603543-	1	20
95	65	30	H165653013-	H165653043-	1	20
100	30	70	H165307013-	H165307043-	1	20
100	35	65	H165356513-	H165356543-	1	20
100	40	60	H165406013-	H165406043-	1	20
100	45	55	H165455513-	H165455543-	1	20
100	50	50	H165505013-	H165505043-	1	20
100	55	45	H165554513-	H165554543-	1	20
100	60	40	H165604013-	H165604043-	1	20
100	65	35	H165653513-	H165653543-	1	20
100	70	30	H165703013-	H165703043-	1	20
60	30	30	H165303012-	H165303042-	1	20
65	30	35	H165303512-	H165303542-	1	20
65	35	30	H165353012-	H165353042-	1	20
70	30	40	H165304012-	H165304042-	1	20
70	35	35	H165353512-	H165353542-	1	20
70	40	30	H165403012-	H165403042-	1	20
75	30	45	H165304512-	H165304542-	1	20
75	35	40	H165354012-	H165354042-	1	20
75	40	35	H165403512-	H165403542-	1	20
75	45	30	H165453012-	H165453042-	1	20
80	30	50	H165305012-	H165305042-	1	20
80	35	45	H165354512-	H165354542-	1	20
80	40	40	H166354512-	H165404042-	1	20
80	45	35	H165453512-	H165453542-	1	20
80	50	30	H165503012-	H165503042-	1	20
85	30	55	H165305512-	H165305542-	1	20
85	35	50	H165355012-	H165355042-	1	20
85	40	45	H165404512-	H165404542-	1	20
85	45	40	H165454012-	H165454042-	1	20
85	50	35	H165503512-	H165503542-	1	20
85	55	30	H165553012-	H165553042-	1	20
90	30	60	H165306012-	H165306042-	1	20
90	35	55	H165355512-	H165355542-	1	20
90	40	50	H165405012-	H165405042-	1	20
90	45	45	H165454512-	H165454542-	1	20
90	50	40	H165504012-	H165504042-	1	20
90	55	35	H165553512-	H165553542-	1	20
90	60	30	H165603012-	H165603042-	1	20
95	30	65	H165306512-	H165306542-	1	20
95	35	60	H165356012-	H165356042-	1	20
95	40	55	H165405512-	H165405542-	1	20
95	45	50	H165455012-	H165455042-	1	20
95	50	45	H165504512-	H165504542-	1	20
95	55	40	H165554012-	H165554042-	1	20
95	60	35	H165603512-	H165603542-	1	20
95	65	30	H165653012-	H165653042-	1	20
100	30	70	H165307012-	H165307042-	1	20
100	35	65	H165356512-	H165356542-	1	20
100	40	60	H165406012-	H165406042-	1	20
100	45	55	H165455512-	H165455542-	1	20
100	50	50	H165505012-	H165505042-	1	20
100	55	45	H165554512-	H165554542-	1	20
100	60	40	H165604012-	H165604042-	1	20
100	65	35	H165653512-	H165653542-	1	20
100	70	30	H165703012-	H165703042-	1	20

Otras medidas consulta



MOD S6 **ART. HS6**



ES

CARACTERÍSTICAS TÉCNICAS:

- Cuerpo de latón
- Rotores de latón
- Leva DIN sobresalientes 30° de acero sinterizado autolubricante
- 6 Pernos de latón
- Contrapernos de latón
- Muelles de acero inoxidable

LLAVES PLANAS

REVERSIBLES:

- De latón niquelado
- Llave larga
- Cifrado de código asignado en la cabeza de la llave

NORMAS:

- Conforme a la norma EN 1303:2005
- Durabilidad : grado 5
- 30.000 cifrados

DOTACIÓN:

- 5 llaves
- Tornillo de fijación 5MAx50

ACABADOS:

- Latón
- Latón niquelado satinado
- Acabados especiales bajo pedido

MOD S6 ART. HS6 PRO MEDIO

MEDIO CILINDRO



LEVA LARGA 15mm.

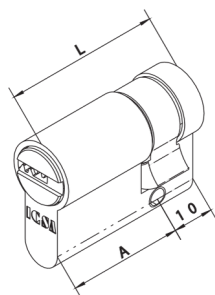

L mm	A mm	B mm	COD. LATON	COD. NIQUEL		
40	30	10	H076301013-	H076301043-	1	20
45	35	10	H076351013-	H076351043-	1	20
50	40	10	H076401013-	H076401043-	1	20
55	45	10	H076451013-	H076451043-	1	20
60	50	10	H076501013-	H076501043-	1	20
65	55	10	H076551013-	H076551043-	1	20
70	60	10	H076601013-	H076601043-	1	20
75	65	10	H076651013-	H076651043-	1	20
80	70	10	H076701013-	H076701043-	1	20
85	75	10	H076751013-	H076751043-	1	20
90	80	10	H076801013-	H076801043-	1	20
95	85	10	H076851013-	H076851043-	1	20
100	90	10	H076901013-	H076901043-	1	20

LEVA CORTA 13mm..

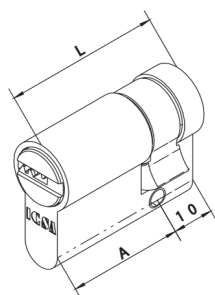

L mm	A mm	B mm	COD. LATON	COD. NIQUEL		
40	30	10	H076301012-	H076301042-	1	20
45	35	10	H076351012-	H076351042-	1	20
50	40	10	H076401012-	H076401042-	1	20
55	45	10	H076451012-	H076451042-	1	20
60	50	10	H076501012-	H076501042-	1	20
65	55	10	H076551012-	H076551042-	1	20
70	60	10	H076601012-	H076601042-	1	20
75	65	10	H076651012-	H076651042-	1	20
80	70	10	H076701012-	H076701042-	1	20
85	75	10	H076751012-	H076751042-	1	20
90	80	10	H076801012-	H076801042-	1	20
95	85	10	H076851012-	H076851042-	1	20
100	90	10	H076901012-	H076901042-	1	20

Otras medidas consultar

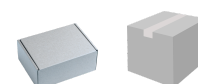

LEVA LARGA 15mm.

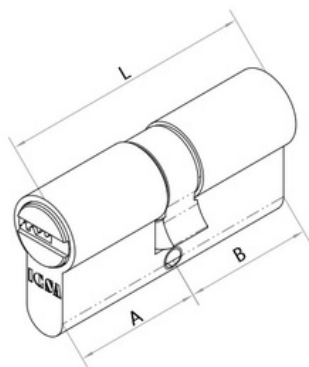

L mm	A mm	B mm	COD. LATON	COD. NIQUEL		
60	30	30	0151303013-	0151303043-	1	20
65	30	35	0151303513-	0151303543-	1	20
70	30	40	0151304013-	0151304043-	1	20
70	35	35	0151353513-	0151353543-	1	20
75	30	45	0151304513-	0151304543-	1	20
75	35	40	0151354013-	0151354043-	1	20
80	30	50	0151305013-	0151305043-	1	20
80	35	45	0151354513-	0151354543-	1	20
80	40	40	0151404013-	0151404043-	1	20
85	30	55	0151305513-	0151305543-	1	20
85	35	50	0151355013-	0151355043-	1	20
85	40	45	0151404513-	0151404543-	1	20
90	30	60	0151306013-	0151306043-	1	20
90	35	55	0151355513-	0151355543-	1	20
90	40	50	0151405013-	0151405043-	1	20
90	45	45	0151454513-	0151454543-	1	20
95	30	65	0151306513-	0151306543-	1	20
95	35	60	0151356013-	0151356043-	1	20
95	40	55	0151405513-	0151405543-	1	20
95	45	50	0151455013-	0151455043-	1	20
100	30	70	0151307013-	0151307043-	1	20
100	35	65	0151356513-	0151356543-	1	20
100	40	60	0151406013-	0151406043-	1	20
100	45	55	0151455513-	0151455543-	1	20
100	50	50	0151505013-	0151505043-	1	20
105	30	75	0151307513-	0151307543-	1	20
105	35	70	0151357013-	0151357043-	1	20
105	50	55	0151505513-	0151505543-	1	20
110	30	80	0151308013-	0151308043-	1	20
110	40	70	0151407013-	0151407043-	1	20
110	50	60	0151506013-	0151506043-	1	20
110	55	55	0151555513-	0151555543-	1	20
115	30	85	0151308513-	0151308543-	1	20
115	40	75	0151407513-	0151407543-	1	20
115	50	65	0151506513-	0151506543-	1	20
120	50	70	0151507013-	0151507043-	1	20
120	55	65	0151556513-	0151556543-	1	20
120	60	60	0151606013-	0151606043-	1	20

LEVA CORTA 13mm.

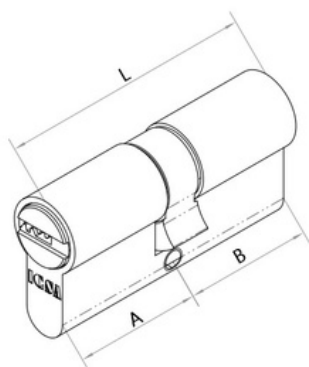

60	30	30	0151303012-	0151303042-	1	20
65	30	35	0151303512-	0151303542-	1	20
70	30	40	0151304012-	0151304042-	1	20
70	35	35	0151353512-	0151353542-	1	20
75	30	45	0151304512-	0151304542-	1	20
75	35	40	0151354012-	0151354042-	1	20
80	30	50	0151305012-	0151305042-	1	20
80	35	45	0151354512-	0151354542-	1	20
80	40	40	0151404012-	0151404042-	1	20
85	30	55	0151305512-	0151305542-	1	20
85	35	50	0151355012-	0151355042-	1	20
85	40	45	0151404512-	0151404542-	1	20
90	30	60	0151306012-	0151306042-	1	20
90	35	55	0151355512-	0151355542-	1	20
90	40	50	0151405012-	0151405042-	1	20
90	45	45	0151454512-	0151454542-	1	20
95	30	65	0151306512-	0151306542-	1	20
95	35	60	0151356012-	0151356042-	1	20
95	40	55	0151405512-	0151405542-	1	20
95	45	50	0151455012-	0151455042-	1	20
100	30	70	0151307012-	0151307042-	1	20
100	35	65	0151356512-	0151356542-	1	20
100	40	60	0151406012-	0151406042-	1	20
100	45	55	0151455512-	0151455542-	1	20
100	50	50	0151505012-	0151505042-	1	20
105	30	75	0151307512-	0151307542-	1	20
105	35	70	0151357012-	0151357042-	1	20
105	50	55	0151505512-	0151505542-	1	20
110	30	80	0151308012-	0151308042-	1	20
110	40	70	0151407012-	0151407042-	1	20
110	50	60	0151506012-	0151506042-	1	20
110	55	55	0151555512-	0151555542-	1	20
115	30	85	0151308512-	0151308542-	1	20
115	40	75	0151407512-	0151407542-	1	20
115	50	65	0151506512-	0151506542-	1	20
120	50	70	0151507012-	0151507042-	1	20
120	55	65	0151556512-	0151556542-	1	20
120	60	60	0151606012-	0151606042-	1	20

Otras medidas bajo pedido

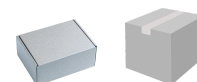

LEVA LARGA 15mm.

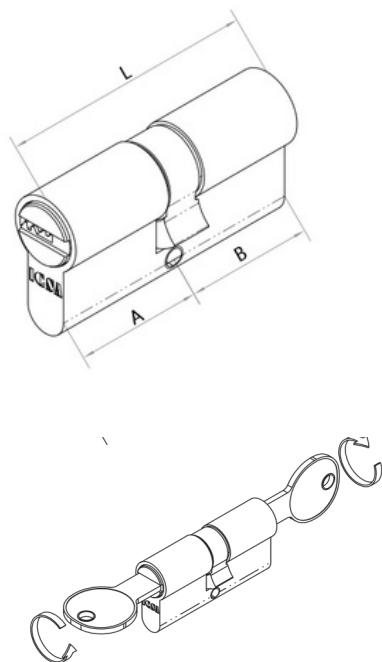

L mm	A mm	B mm	COD. LATON	COD. NIQUEL		
60	30	30	0152303013-	0152303043-	1	20
65	30	35	0152303513-	0152303543-	1	20
70	30	40	0152304013-	0152304043-	1	20
70	35	35	0152353513-	0152353543-	1	20
75	30	45	0152304513-	0152304543-	1	20
75	35	40	0152354013-	0152354043-	1	20
80	30	50	0152305013-	0152305043-	1	20
80	35	45	0152354513-	0152354543-	1	20
80	40	40	0152404013-	0152404043-	1	20
85	30	55	0152305513-	0152305543-	1	20
85	35	50	0152355013-	0152355043-	1	20
85	40	45	0152404513-	0152404543-	1	20
90	30	60	0152306013-	0152306043-	1	20
90	35	55	0152355513-	0152355543-	1	20
90	40	50	0152405013-	0152405043-	1	20
90	45	45	0152454513-	0152454543-	1	20
95	30	65	0152306513-	0152306543-	1	20
95	35	60	0152356013-	0152356043-	1	20
95	40	55	0152405513-	0152405543-	1	20
95	45	50	0152455013-	0152455043-	1	20
100	30	70	0152307013-	0152307043-	1	20
100	35	65	0152356513-	0152356543-	1	20
100	40	60	0152406013-	0152406043-	1	20
100	45	55	0152455513-	0152455543-	1	20
100	50	50	0152505013-	0152505043-	1	20
105	30	75	0152307513-	0152307543-	1	20
105	35	70	0152357013-	0152357043-	1	20
105	50	55	0152505513-	0152505543-	1	20
110	30	80	0152308013-	0152308043-	1	20
110	40	70	0152407013-	0152407043-	1	20
110	50	60	0152506013-	0152506043-	1	20
110	55	55	0152555513-	0152555543-	1	20
115	30	85	0152308513-	0152308543-	1	20
115	40	75	0152407513-	0152407543-	1	20
115	50	65	0152506513-	0152506543-	1	20

LEVA CORTA 13mm.

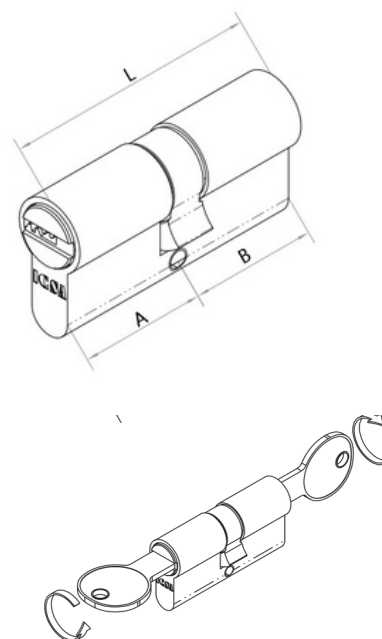

60	30	30	0152303012-	0152303042-	1	20
65	30	35	0152303512-	0152303542-	1	20
70	30	40	0152304012-	0152304042-	1	20
70	35	35	0152353512-	0152353542-	1	20
75	30	45	0152304512-	0152304542-	1	20
75	35	40	0152354012-	0152354042-	1	20
80	30	50	0152305012-	0152305042-	1	20
80	35	45	0152354512-	0152354542-	1	20
80	40	40	0152404012-	0152404042-	1	20
85	30	55	0152305512-	0152305542-	1	20
85	35	50	0152355012-	0152355042-	1	20
85	40	45	0152404512-	0152404542-	1	20
90	30	60	0152306012-	0152306042-	1	20
90	35	55	0152355512-	0152355542-	1	20
90	40	50	0152405012-	0152405042-	1	20
90	45	45	0152454512-	0152454542-	1	20
95	30	65	0152306512-	0152306542-	1	20
95	35	60	0152356012-	0152356042-	1	20
95	40	55	0152405512-	0152405542-	1	20
95	45	50	0152455012-	0152455042-	1	20
100	30	70	0152307012-	0152307042-	1	20
100	35	65	0152356512-	0152356542-	1	20
100	40	60	0152406012-	0152406042-	1	20
100	45	55	0152455512-	0152455542-	1	20
100	50	50	0152505012-	0152505042-	1	20
105	30	75	0152307512-	0152307542-	1	20
105	35	70	0152357012-	0152357042-	1	20
105	50	55	0152505512-	0152505542-	1	20
110	30	80	0152308012-	0152308042-	1	20
110	40	70	0152407012-	0152407042-	1	20
110	50	60	0152506012-	0152506042-	1	20
110	55	55	0152555512-	0152555542-	1	20
115	30	85	0152308512-	0152308542-	1	20
115	40	75	0152407512-	0152407542-	1	20
115	50	65	0152506512-	0152506542-	1	20

Otras medidas consultar

MOD S6 ART. HS6 168Z

DOBLE POMO CON POMO

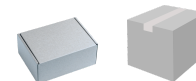

LEVA LARGA 15mm.

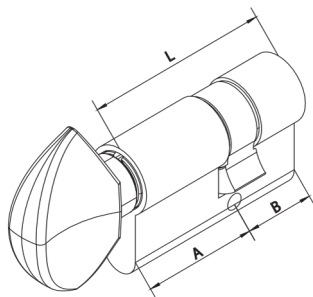

POMO EN ZAMAK

LEVA CORTA 13mm.

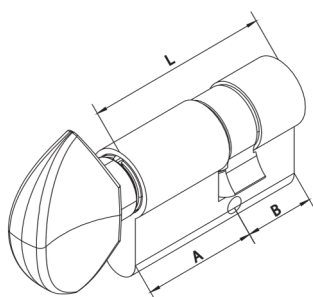

POMO ZAMAK

L mm	A mm	B mm	COD. LATON	COD. NIQUEL		
60	30	30	0165303013-	0165303043-	1	20
65	30	35	0165303513-	0165303543-	1	20
65	35	30	0165353013-	0165353043-	1	20
70	30	40	0165304013-	0165304043-	1	20
70	35	35	0165353513-	0165353543-	1	20
70	40	30	0165403013-	0165403043-	1	20
75	30	45	0165304513-	0165304543-	1	20
75	35	40	0165354013-	0165354043-	1	20
75	40	35	0165403513-	0165403543-	1	20
75	45	30	0165453013-	0165453043-	1	20
80	30	50	0165305013-	0165305043-	1	20
80	35	45	0165354513-	0165354543-	1	20
80	40	40	0165404013-	0165404043-	1	20
80	45	35	0165453513-	0165453543-	1	20
80	50	30	0165503013-	0165503043-	1	20
85	30	55	0165305513-	0165305543-	1	20
85	35	50	0165355013-	0165355043-	1	20
85	40	45	0165404513-	0165404543-	1	20
85	45	40	0165454013-	0165454043-	1	20
85	50	35	0165503513-	0165503543-	1	20
85	55	30	0165553013-	0165553043-	1	20
90	30	60	0165306013-	0165306043-	1	20
90	35	55	0165355513-	0165355543-	1	20
90	40	50	0165405013-	0165405043-	1	20
90	45	45	0165454513-	0165454543-	1	20
90	50	40	0165504013-	0165504043-	1	20
90	55	35	0165553513-	0165553543-	1	20
90	60	30	0165603013-	0165603043-	1	20
95	30	65	0165306513-	0165306543-	1	20
95	35	60	0165356013-	0165356043-	1	20
95	40	55	0165405513-	0165405543-	1	20
95	45	50	0165455013-	0165455043-	1	20
95	50	45	0165504513-	0165504543-	1	20
95	55	40	0165554013-	0165554043-	1	20
95	60	35	0165603513-	0165603543-	1	20
95	65	30	0165653013-	0165653043-	1	20
100	30	70	0165307013-	0165307043-	1	20
100	35	65	0165356513-	0165356543-	1	20
100	40	60	0165406013-	0165406043-	1	20
100	45	55	0165455513-	0165455543-	1	20
100	50	50	0165505013-	0165505043-	1	20
100	55	45	0165554513-	0165554543-	1	20
100	60	40	0165604013-	0165604043-	1	20
100	65	35	0165653513-	0165653543-	1	20
100	70	30	0165703013-	0165703043-	1	20
60	30	30	0165303012-	0165303042-	1	20
65	30	35	0165303512-	0165303542-	1	20
65	35	30	0165353012-	0165353042-	1	20
70	30	40	0165304012-	0165304042-	1	20
70	35	35	0165353512-	0165353542-	1	20
70	40	30	0165403012-	0165403042-	1	20
75	30	45	0165304512-	0165304542-	1	20
75	35	40	0165354012-	0165354042-	1	20
75	40	35	0165403512-	0165403542-	1	20
75	45	30	0165453012-	0165453042-	1	20
80	30	50	0165305012-	0165305042-	1	20
80	35	45	0165354512-	0165354542-	1	20
80	40	40	0166354512-	0165404042-	1	20
80	45	35	0165453512-	0165453542-	1	20
80	50	30	0165503012-	0165503042-	1	20
85	30	55	0165305512-	0165305542-	1	20
85	35	50	0165355012-	0165355042-	1	20
85	40	45	0165404512-	0165404542-	1	20
85	45	40	0165454012-	0165454042-	1	20
85	50	35	0165503512-	0165503542-	1	20
85	55	30	0165553012-	0165553042-	1	20
85	60	25	0165603012-	0165603042-	1	20
90	35	55	0165355512-	0165355542-	1	20
90	40	50	0165405012-	0165405042-	1	20
90	45	45	0165454512-	0165454542-	1	20
90	50	40	0165504012-	0165504042-	1	20
90	55	35	0165553512-	0165553542-	1	20
90	60	30	0165603012-	0165603042-	1	20
95	30	65	0165306512-	0165306542-	1	20
95	35	60	0165356012-	0165356042-	1	20
95	40	55	0165405512-	0165405542-	1	20
95	45	50	0165455012-	0165455042-	1	20
95	50	45	0165504512-	0165504542-	1	20
95	55	40	0165554012-	0165554042-	1	20
95	60	35	0165603512-	0165603542-	1	20
95	65	30	0165653012-	0165653042-	1	20
100	30	70	0165307012-	0165307042-	1	20
100	35	65	0165356512-	0165356542-	1	20
100	40	60	0165406012-	0165406042-	1	20
100	45	55	0165455512-	0165455542-	1	20
100	50	50	0165505012-	0165505042-	1	20
100	55	45	0165554512-	0165554542-	1	20
100	60	40	0165604012-	0165604042-	1	20
100	65	35	0165653512-	0165653542-	1	20
100	70	30	0165703012-	0165703042-	1	20

Otras medidas consulta

MOD **S6** ART. **HS6 MEDIO**

MEDIO CILINDRO



LEVA LARGA 15mm.

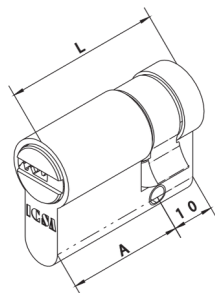

L mm	A mm	B mm	COD. LATON	COD. NIQUEL		
40	30	10	0076301013-	0076301043-	1	20
45	35	10	0076351013-	0076351043-	1	20
50	40	10	0076401013-	0076401043-	1	20
55	45	10	0076451013-	0076451043-	1	20
60	50	10	0076501013-	0076501043-	1	20
65	55	10	0076551013-	0076551043-	1	20
70	60	10	0076601013-	0076601043-	1	20
75	65	10	0076651013-	0076651043-	1	20
80	70	10	0076701013-	0076701043-	1	20
85	75	10	0076751013-	0076751043-	1	20
90	80	10	0076801013-	0076801043-	1	20
95	85	10	0076851013-	0076851043-	1	20
100	90	10	0076901013-	0076901043-	1	20

LEVA CORTA 13mm..

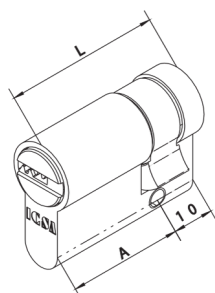

L mm	A mm	B mm	COD. LATON	COD. NIQUEL		
40	30	10	0076301012-	0076301042-	1	20
45	35	10	0076351012-	0076351042-	1	20
50	40	10	0076401012-	0076401042-	1	20
55	45	10	0076451012-	0076451042-	1	20
60	50	10	0076501012-	0076501042-	1	20
65	55	10	0076551012-	0076551042-	1	20
70	60	10	0076601012-	0076601042-	1	20
75	65	10	0076651012-	0076651042-	1	20
80	70	10	0076701012-	0076701042-	1	20
85	75	10	0076751012-	0076751042-	1	20
90	80	10	0076801012-	0076801042-	1	20
95	85	10	0076851012-	0076851042-	1	20
100	90	10	0076901012-	0076901042-	1	20

Otras medidas consultar

MOD S3



CARACTERÍSTICAS

TÉCNICAS: • Cuerpo de latón • Rotores de latón • Leva DIN sobresaliente 30° de

acero sinterizado autolubricante • 6 Pernos de latón (2 pernos de acero inox)

• 4 Contrapernos de latón y 2 en acero inox: 2 ANTI-PICKING y 2 ANTI-BUMPING

• Muelles de acero inoxidable • Insertos de acero templado anti taladro de los rotores

• Pernos de acero templado anti taladro en el cuerpo

LLAVES: • Específicas de latón niquelado • Con numeración de código en la cabeza de la llave



NORMAS: • CERTIFICADO SKG*** • Conforme a la norma EN 1303:2005 • Durabilidad: grado 6 • 100.000 cifrados

DOTACIÓN: • 3 llaves • Tornillo de fijación 5Max65 • Instrucciones ACABADOS: • Latón • Latón niquelado satinado • Acabados especiales bajo pedido

La certificación SKG garantiza que los productos cumplen con los más altos requisitos de seguridad y es un valor añadido clave en materia de anti-vejecimiento. La marca SKG en los productos es una garantía de alta resistencia a las técnicas de rotura más comunes.

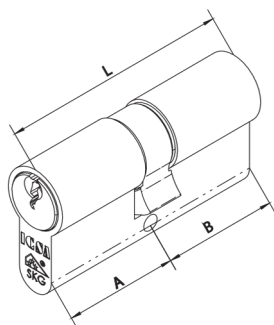
LEVA LARGA 15mm.



L mm	A mm	B mm	COD. LATON	COD. NIQUEL		
60	30	30	0149303013-	0149303043-	1	20
65	30	35	0149303513-	0149303543-	1	20
70	30	40	0149304013-	0149304043-	1	20
70	35	35	0149353513-	0149353543-	1	20
75	30	45	0149304513-	0149304543-	1	20
75	35	40	0149354013-	0149354043-	1	20
80	30	50	0149305013-	0149305043-	1	20
80	35	45	0149354513-	0149354543-	1	20
80	40	40	0149404013-	0149404043-	1	20
85	30	55	0149305513-	0149305543-	1	20
85	35	50	0149355013-	0149355043-	1	20
85	40	45	0149404513-	0149404543-	1	20
90	30	60	0149306013-	0149306043-	1	20
90	35	55	0149355513-	0149355543-	1	20
90	40	50	0149405013-	0149405043-	1	20
90	45	45	0149454513-	0149454543-	1	20
95	30	65	0149306513-	0149306543-	1	20
95	35	60	0149356013-	0149356043-	1	20
95	40	55	0149405513-	0149405543-	1	20
95	45	50	0149455013-	0149455043-	1	20
100	30	70	0149307013-	0149307043-	1	20
100	35	65	0149356513-	0149356543-	1	20
100	40	65	0149406013-	0149406043-	1	20
100	45	55	0149455513-	0149455543-	1	20
100	50	50	0149505013-	0149505043-	1	20
105	30	75	0149307513-	0149307543-	1	20
105	35	70	0149357013-	0149357043-	1	20
105	40	65	0149406513-	0149406543-	1	20
105	45	60	0149456013-	0149456043-	1	20
105	50	55	0149505513-	0149505543-	1	20
110	30	80	0149308013-	0149308043-	1	20
110	35	75	0149357513-	0149357543-	1	20
110	40	70	0149407013-	0149407043-	1	20
110	45	65	0149456513-	0149456543-	1	20
110	50	60	0149506013-	0149506043-	1	20
110	55	55	0149555513-	0149555543-	1	20
115	30	85	0149308513-	0149308543-	1	20
115	35	80	0149358013-	0149358043-	1	20
115	40	75	0149407513-	0149407543-	1	20
115	45	70	0149457013-	0149457043-	1	20
115	50	65	0149506513-	0149506543-	1	20
115	55	60	0149556013-	0149556043-	1	20
120	30	90	0149309013-	0149309043-	1	20
120	35	85	0149358513-	0149358543-	1	20
120	40	80	0149408013-	0149408043-	1	20
120	45	75	0149457513-	0149457543-	1	20
120	50	70	0149507013-	0149507043-	1	20
120	55	65	0149556513-	0149556543-	1	20
120	60	60	0149606013-	0149606043-	1	20
125	35	90	0149359013-	0149359043-	1	20
125	40	85	0149408513-	0149408543-	1	20
125	45	80	0149458013-	0149458043-	1	20
125	50	75	0149507513-	0149507543-	1	20
125	55	70	0149557013-	0149557043-	1	20
125	60	65	0149606513-	0149606543-	1	20
130	40	90	0149409013-	0149409043-	1	20
130	45	85	0149458513-	0149458543-	1	20
130	50	80	0149508013-	0149508043-	1	20
130	55	75	0149557513-	0149557543-	1	20
130	60	70	0149607013-	0149607043-	1	20
130	65	65	0149656513-	0149656543-	1	20

Otras medidas consultar

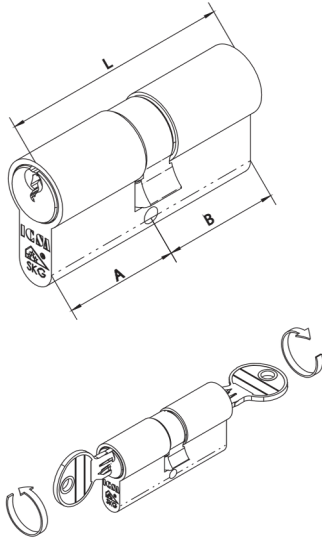
LEVA LARGA 15mm.

L mm	A mm	B mm	COD. LATON	COD. NIQUEL		
60	30	30	F149303013-	F149303043-	1	20
65	30	35	F149303513-	F149303543-	1	20
70	30	40	F149304013-	F149304043-	1	20
70	35	35	F149353513-	F149353543-	1	20
75	30	45	F149304513-	F149304543-	1	20
75	35	40	F149354013-	F149354043-	1	20
80	30	50	F149305013-	F149305043-	1	20
80	35	45	F149354513-	F149354543-	1	20
80	40	40	F149404013-	F149404043-	1	20
85	30	55	F149305513-	F149305543-	1	20
85	35	50	F149355013-	F149355043-	1	20
85	40	45	F149404513-	F149404543-	1	20
90	30	60	F149306013-	F149306043-	1	20
90	35	55	F149355513-	F149355543-	1	20
90	40	50	F149405013-	F149405043-	1	20
90	45	45	F149454513-	F149454543-	1	20
95	30	65	F149306513-	F149306543-	1	20
95	35	60	F149356013-	F149356043-	1	20
95	40	55	F149405513-	F149405543-	1	20
95	45	50	F149455013-	F149455043-	1	20
100	30	70	F149307013-	F149307043-	1	20
100	35	65	F149356513-	F149356543-	1	20
100	40	65	F149406013-	F149406043-	1	20
100	45	55	F149455513-	F149455543-	1	20
100	50	50	F149505013-	F149505043-	1	20
105	30	75	F149307513-	F149307543-	1	20
105	35	70	F149357013-	F149357043-	1	20
105	40	65	F149406513-	F149406543-	1	20
105	45	60	F149456013-	F149456043-	1	20
105	50	55	F149505513-	F149505543-	1	20
110	30	80	F149308013-	F149308043-	1	20
110	35	75	F149357513-	F149357543-	1	20
110	40	70	F149407013-	F149407043-	1	20
110	45	65	F149456513-	F149456543-	1	20
110	50	60	F149506013-	F149506043-	1	20
110	55	55	F149555513-	F149555543-	1	20
115	30	85	F149308513-	F149308543-	1	20
115	35	80	F149358013-	F149358043-	1	20
115	40	75	F149407513-	F149407543-	1	20
115	45	70	F149457013-	F149457043-	1	20
115	50	65	F149506513-	F149506543-	1	20
115	55	60	F149556013-	F149556043-	1	20
120	30	90	F149309013-	F149309043-	1	20
120	35	85	F149358513-	F149358543-	1	20
120	40	80	F149408013-	F149408043-	1	20
120	45	75	F149457513-	F149457543-	1	20
120	50	70	F149507013-	F149507043-	1	20
120	55	65	F149556513-	F149556543-	1	20
120	60	60	F149606013-	F149606043-	1	20
125	35	90	F149359013-	F149359043-	1	20
125	40	85	F149408513-	F149408543-	1	20
125	45	80	F149458013-	F149458043-	1	20
125	50	75	F149507513-	F149507543-	1	20
125	55	70	F149557013-	F149557043-	1	20
125	60	65	F149606513-	F149606543-	1	20
130	40	90	F149409013-	F149409043-	1	20
130	45	85	F149458513-	F149458543-	1	20
130	50	80	F149508013-	F149508043-	1	20
130	55	75	F149557513-	F149557543-	1	20
130	60	70	F149607013-	F149607043-	1	20
130	65	65	F149656513-	F149656543-	1	20

Otras medidas consultar

LEVA LARGA 15mm.

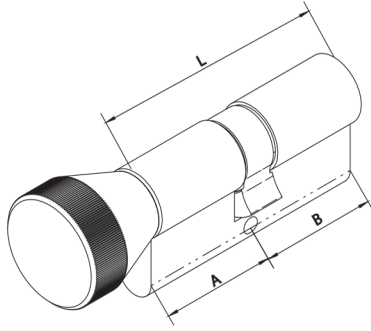

POMO EN LATON

L mm	A mm	B mm	COD. LATON	COD. NIQUEL		
60	30	30	0164303013-	0164303043-	1	20
65	30	35	0164303513-	0164303543-	1	20
65	35	30	0164353013-	0164353043-	1	20
70	30	40	0164304013-	0164304043-	1	20
70	35	35	0164353513-	0164353543-	1	20
70	40	30	0164403013-	0164403043-	1	20
75	30	45	0164304513-	0164304543-	1	20
75	35	40	0164354013-	0164354043-	1	20
75	40	35	0164403513-	0164403543-	1	20
75	45	30	0164453013-	0164453043-	1	20
80	30	50	0164305013-	0164305043-	1	20
80	35	45	0164354513-	0164354543-	1	20
80	40	40	0164404013-	0164404043-	1	20
80	45	35	0164453513-	0164453543-	1	20
80	50	30	0164503013-	0164503043-	1	20
85	30	55	0164305513-	0164305543-	1	20
85	35	50	0164355013-	0164355043-	1	20
85	40	45	0164404513-	0164404543-	1	20
85	45	40	0164454013-	0164454043-	1	20
85	50	35	0164503513-	0164503543-	1	20
85	55	30	0164553013-	0164553043-	1	20
90	30	60	0164306013-	0164306043-	1	20
90	35	55	0164355513-	0164355543-	1	20
90	40	50	0164405013-	0164405043-	1	20
90	45	45	0164454513-	0164454543-	1	20
90	50	40	0164504013-	0164504043-	1	20
90	55	35	0164553513-	0164553543-	1	20
90	60	30	0164603013-	0164603043-	1	20
95	30	65	0164306513-	0164306543-	1	20
95	35	60	0164356013-	0164356043-	1	20
95	40	55	0164405513-	0164405543-	1	20
95	45	50	0164455013-	0164455043-	1	20

Otras medidas consultar



MOD **S3** ART. **78** MEDIO CILINDRO
MEDIO CILINDRO DE SEGURIDAD CERTIFICADO SKG***



LEVA LARGA 15mm.

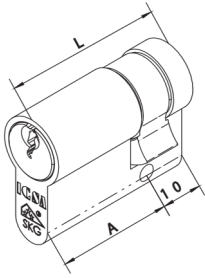

L mm	A mm	B mm	COD. LATON	COD. NIQUEL		
40	30	10	0078301013-	0078301043-	1	20
45	35	10	0078351013-	0078351043-	1	20
50	40	10	0078401013-	0078401043-	1	20
55	45	10	0078451013-	0078451043-	1	20
60	50	10	0078501013-	0078501043-	1	20
65	55	10	0078551013-	0078551043-	1	20
70	60	10	0078601013-	0078601043-	1	20
75	65	10	0078651013-	0078651043-	1	20
80	70	10	0078701013-	0078701043-	1	20
85	75	10	0078751013-	0078751043-	1	20
90	80	10	0078801013-	0078801043-	1	20
95	85	10	0078851013-	0078851043-	1	20
100	90	10	0078901013-	0078901043-	1	20
105	95	10	0078951013-	0078951043-	1	20
110	100	10	00781001013-	00781001043-	1	20

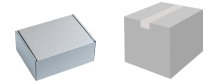

Otras medidas consultar



MOD C5



ES

CARACTERÍSTICAS TÉCNICAS:

- Cuerpo de latón
- Rotores de latón
- Leva DIN sobresaliente 30° de acero sinterizado autolubricante
- Levas redondas de acero sinterizado autolubricante bajo pedido
- 5 Pernos de latón (27/27 - 27/33 4 pernos)
- Contrapernos de latón
- Muelles de acero inoxidable

LLAVES:

- De latón niquelado

NORMAS:

- Conforme a la norma EN 1303:2005
- Durabilidad: grado 5
- 30.000 cifrados

DOTACIÓN:

- 3 llaves
- Tornillo de fijación 5MAx50

ACABADOS:

- Latón
- Latón niquelado satinado
- Latón niquel brillo
- Acabados especiales bajo

pedido



LEVA LARGA 15mm.

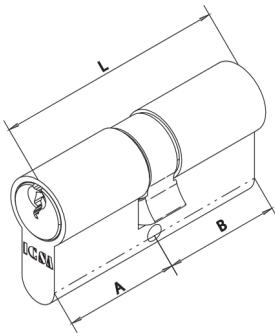

LEVA CORTA 13mm.

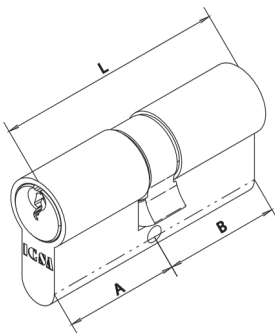

Otras medidas consultar

L mm	A mm	B mm	COD. LATON	COD. NIQUEL		
54	27	27	0150272713-	0150272723-	1	20
60	27	33	0150273313-	0150273323-	1	20
60	30	30	0150303013-	0150303023-	1	20
65	30	35	0150303513-	0150303523-	1	20
70	30	40	0150304013-	0150304023-	1	20
70	35	35	0150353513-	0150353523-	1	20
75	30	45	0150304513-	0150304523-	1	20
75	35	40	0150354013-	0150354023-	1	20
80	30	50	0150305013-	0150305023-	1	20
80	35	45	0150354513-	0150354523-	1	20
80	40	40	0150404013-	0150404023-	1	20
85	30	55	0150305513-	0150305523-	1	20
85	35	50	0150355013-	0150355023-	1	20
85	40	45	0150404513-	0150404523-	1	20
90	30	60	0150306013-	0150306023-	1	20
90	35	55	0150355513-	0150355523-	1	20
90	40	50	0150405013-	0150405023-	1	20
90	45	45	0150454513-	0150454523-	1	20
95	30	65	0150306513-	0150306523-	1	20
95	35	60	0150356013-	0150356023-	1	20
95	40	55	0150405513-	0150405523-	1	20
95	45	50	0150455013-	0150455023-	1	20
100	30	70	0150307013-	0150307023-	1	20
100	35	65	0150356513-	0150356523-	1	20
100	40	60	0150406013-	0150406023-	1	20
100	45	55	0150455513-	0150455523-	1	20
100	50	50	0150505013-	0150505023-	1	20
105	30	75	0150307513-	0150307523-	1	20
105	35	70	0150357013-	0150357023-	1	20
105	50	55	0150505513-	0150505523-	1	20
110	30	80	0150308013-	0150308023-	1	20
110	40	70	0150407013-	0150407023-	1	20
110	50	60	0150506013-	0150506023-	1	20
110	55	55	0150555513-	0150555523-	1	20
115	30	85	0150308513-	0150308523-	1	20
115	40	75	0150407513-	0150407523-	1	20
115	50	65	0150506513-	0150506523-	1	20
120	50	70	0150507013-	0150507023-	1	20
120	55	65	0150556513-	0150556523-	1	20
120	60	60	0150606013-	0150606023-	1	20
60	30	30	0150303012-	0150303022-	1	20
65	30	35	0150303512-	0150303522-	1	20
70	30	40	0150304012-	0150304022-	1	20
70	35	35	0150353512-	0150353522-	1	20
75	30	45	0150304512-	0150304522-	1	20
75	35	40	0150354012-	0150354022-	1	20
80	30	50	0150305012-	0150305022-	1	20
80	35	45	0150354512-	0150354522-	1	20
80	40	40	0150404012-	0150404022-	1	20
85	30	55	0150305512-	0150305522-	1	20
85	35	50	0150355012-	0150355022-	1	20
85	40	45	0150404512-	0150404522-	1	20
90	30	60	0150306012-	0150306022-	1	20
90	35	55	0150355512-	0150355522-	1	20
90	40	50	0150405012-	0150405022-	1	20
90	45	45	0150454512-	0150454522-	1	20
95	30	65	0150306512-	0150306522-	1	20
95	35	60	0150356012-	0150356022-	1	20
95	40	55	0150405512-	0150405522-	1	20
95	45	50	0150455012-	0150455022-	1	20
100	30	70	0150307012-	0150307022-	1	20
100	35	65	0150356512-	0150356522-	1	20
100	40	60	0150406012-	0150406022-	1	20
100	45	55	0150455512-	0150455522-	1	20
100	50	50	0150505012-	0150505022-	1	20
105	30	75	0150307512-	0150307522-	1	20
105	35	70	0150357012-	0150357022-	1	20
105	50	55	0150505512-	0150505522-	1	20
110	30	80	0150308012-	0150308022-	1	20
110	40	70	0150407012-	0150407022-	1	20
110	50	60	0150506012-	0150506022-	1	20
110	55	55	0150555512-	0150555522-	1	20
115	30	85	0150308512-	0150308522-	1	20
115	40	75	0150407512-	0150407522-	1	20
115	50	65	0150506512-	0150506522-	1	20
120	50	70	0150507012-	0150507022-	1	20
120	55	65	0150556512-	0150556522-	1	20
120	60	60	0150606012-	0150606022-	1	20

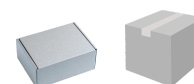

LEVA LARGA 15mm.

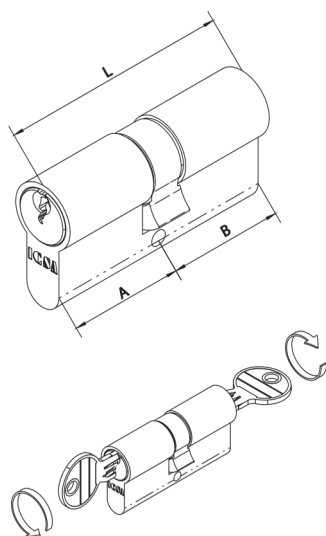

L mm	A mm	B mm	COD. LATON	COD. NIQUEL	1	20
60	30	30	0139303013-	0139303023-	1	20
65	30	35	0139303513-	0139303523-	1	20
70	30	40	0139304013-	0139304023-	1	20
70	35	35	0139353513-	0139353523-	1	20
75	30	45	0139304513-	0139304523-	1	20
75	35	40	0139354013-	0139354023-	1	20
80	30	50	0139305013-	0139305023-	1	20
80	35	45	0139354513-	0139354523-	1	20
80	40	40	0139404013-	0139404023-	1	20
85	30	55	0139305513-	0139305523-	1	20
85	35	50	0139355013-	0139355023-	1	20
85	40	45	0139404513-	0139404523-	1	20
90	30	60	0139306013-	0139306023-	1	20
90	35	55	0139355513-	0139355523-	1	20
90	40	50	0139405013-	0139405023-	1	20
90	45	45	0139454513-	0139454523-	1	20
95	30	65	0139306513-	0139306523-	1	20
95	35	60	0139356013-	0139356023-	1	20
95	40	55	0139405513-	0139405523-	1	20
95	45	50	0139455013-	0139455023-	1	20
100	30	70	0139307013-	0139307023-	1	20
100	35	65	0139356513-	0139356523-	1	20
100	40	60	0139406013-	0139406023-	1	20
100	45	55	0139455513-	0139455523-	1	20
100	50	50	0139505013-	0139505023-	1	20
105	30	75	0139307513-	0139307523-	1	20
105	35	70	0139357013-	0139357023-	1	20
105	50	55	0139505513-	0139505523-	1	20
110	30	80	0139308013-	0139308023-	1	20
110	40	70	0139407013-	0139407023-	1	20
110	50	60	0139506013-	0139506023-	1	20
110	55	55	0139555513-	0139555523-	1	20
115	30	85	0139308513-	0139308523-	1	20
115	40	75	0139407513-	0139407523-	1	20
115	50	65	0139506513-	0139506523-	1	20

**LEVA CORTA 13.2 mm.
SHORT 13.2 CAM
LEVA CORTA
LEVIER COURT**

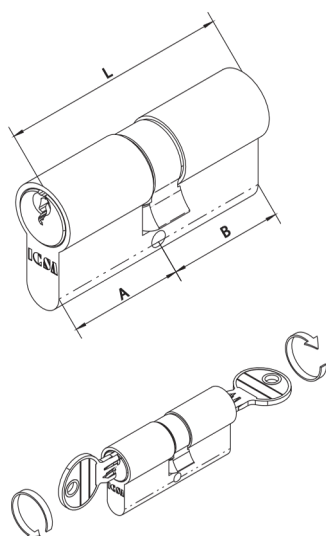

L mm	A mm	B mm	COD. LATON	COD. NIQUEL	1	20
60	30	30	0139303012-	0139303022-	1	20
65	30	35	0139303512-	0139303522-	1	20
70	30	40	0139304012-	0139304022-	1	20
70	35	35	0139353512-	0139353522-	1	20
75	30	45	0139304512-	0139304522-	1	20
75	35	40	0139354012-	0139354022-	1	20
80	30	50	0139305012-	0139305022-	1	20
80	35	45	0139354512-	0139354522-	1	20
80	40	40	0139404012-	0139404022-	1	20
85	30	55	0139305512-	0139305522-	1	20
85	35	50	0139355012-	0139355022-	1	20
85	40	45	0139404512-	0139404522-	1	20
90	30	60	0139306012-	0139306022-	1	20
90	35	55	0139355512-	0139355522-	1	20
90	40	50	0139405012-	0139405022-	1	20
90	45	45	0139454512-	0139454522-	1	20
95	30	65	0139306512-	0139306522-	1	20
95	35	60	0139356012-	0139356022-	1	20
95	40	55	0139405512-	0139405522-	1	20
95	45	50	0139455012-	0139455022-	1	20
100	30	70	0139307012-	0139307022-	1	20
100	35	65	0139356512-	0139356522-	1	20
100	40	60	0139406012-	0139406022-	1	20
100	45	55	0139455512-	0139455522-	1	20
100	50	50	0139505012-	0139505022-	1	20
105	30	75	0139307512-	0139307522-	1	20
105	35	70	0139357012-	0139357022-	1	20
105	50	55	0139505512-	0139505522-	1	20
110	30	80	0139308012-	0139308022-	1	20
110	40	70	0139407012-	0139407022-	1	20
110	50	60	0139506012-	0139506022-	1	20
110	55	55	0139555512-	0139555522-	1	20
115	30	85	0139308512-	0139308522-	1	20
115	40	75	0139407512-	0139407522-	1	20
115	50	65	0139506512-	0139506522-	1	20

Altre misure a richiesta
Other dimensions on request
Otras medida bajo pedido
Autres mesures à la demande

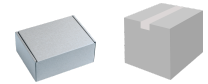

LEVA LARGA 15mm

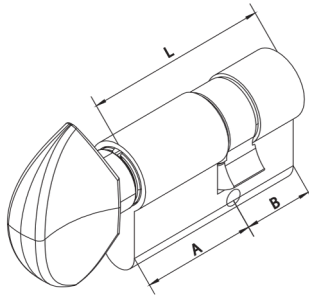

POMO ZAMAK

L mm	A mm	B mm	COD. LATON	COD. NIQUEL		
60	30	30	Z168303013-	Z168303043-	1	20
65	30	35	Z168303513-	Z168303543-	1	20
70	30	40	Z168304013-	Z168304043-	1	20
70	35	35	Z168353513-	Z168353543-	1	20
75	30	45	Z168304513-	Z168304543-	1	20
75	35	40	Z168354013-	Z168354043-	1	20
80	30	50	Z168305013-	Z168305043-	1	20
80	35	45	Z168354513-	Z168354543-	1	20
80	40	40	Z168404013-	Z168404043-	1	20
85	30	55	Z168305513-	Z168305543-	1	20
85	35	50	Z168355013-	Z168355043-	1	20
85	40	45	Z168404513-	Z168404543-	1	20
90	30	60	Z168306013-	Z168306043-	1	20
90	35	55	Z168355513-	Z168355543-	1	20
90	40	50	Z168405013-	Z168405043-	1	20
90	45	45	Z168454513-	Z168454543-	1	20
95	30	65	Z168306513-	Z168306543-	1	20
95	35	60	Z168356013-	Z168356043-	1	20
95	40	55	Z168405513-	Z168405543-	1	20
95	45	50	Z168455013-	Z168455043-	1	20
100	30	70	Z168307013-	Z168307043-	1	20
100	35	65	Z168356513-	Z168356543-	1	20
100	40	60	Z168406013-	Z168406043-	1	20
100	45	55	Z168455513-	Z168455543-	1	20
100	50	50	Z168505013-	Z168505043-	1	20
105	30	75	Z168307513-	Z168307543-	1	20
105	35	70	Z168357013-	Z168357043-	1	20
105	50	55	Z168505513-	Z168505543-	1	20
110	30	80	Z168308013-	Z168308043-	1	20
110	40	70	Z168407013-	Z168407043-	1	20
110	50	60	Z168506013-	Z168506043-	1	20
110	55	55	Z168555513-	Z168555543-	1	20
115	30	85	Z168308513-	Z168308543-	1	20
115	40	75	Z168407513-	Z168407543-	1	20
115	50	65	Z168506513-	Z168506543-	1	20

LEVA CORTA 13mm.

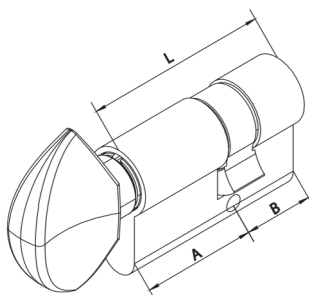

POMO ZAMAK



L mm	A mm	B mm	COD. LATON	COD. NIQUEL		
60	30	30	Z168303012-	Z168303042-	1	20
65	30	35	Z168303512-	Z168303542-	1	20
70	30	40	Z168304012-	Z168304042-	1	20
70	35	35	Z168353512-	Z168353542-	1	20
75	30	45	Z168304512-	Z168304542-	1	20
75	35	40	Z168354012-	Z168354042-	1	20
80	30	50	Z168305012-	Z168305042-	1	20
80	35	45	Z168354512-	Z168354542-	1	20
80	40	40	Z168404012-	Z168404042-	1	20
85	30	55	Z168305512-	Z168305542-	1	20
85	35	50	Z168355012-	Z168355042-	1	20
85	40	45	Z168404512-	Z168404542-	1	20
90	30	60	Z168306012-	Z168306042-	1	20
90	35	55	Z168355512-	Z168355542-	1	20
90	40	50	Z168405012-	Z168405042-	1	20
90	45	45	Z168454512-	Z168454542-	1	20
95	30	65	Z168306512-	Z168306542-	1	20
95	35	60	Z168356012-	Z168356042-	1	20
95	40	55	Z168405512-	Z168405542-	1	20
95	45	50	Z168455012-	Z168455042-	1	20
100	30	70	Z168307012-	Z168307042-	1	20
100	35	65	Z168356512-	Z168356542-	1	20
100	40	60	Z168406012-	Z168406042-	1	20
100	45	55	Z168455512-	Z168455542-	1	20
100	50	50	Z168505012-	Z168505042-	1	20
105	30	75	Z168307512-	Z168307542-	1	20
105	35	70	Z168357012-	Z168357042-	1	20
105	50	55	Z168505512-	Z168505542-	1	20
110	30	80	Z168308012-	Z168308042-	1	20
110	40	70	Z168407012-	Z168407042-	1	20
110	50	60	Z168506012-	Z168506042-	1	20
110	55	55	Z168555512-	Z168555542-	1	20
115	30	85	Z168308512-	Z168308542-	1	20
115	40	75	Z168407512-	Z168407542-	1	20
115	50	65	Z168506512-	Z168506542-	1	20

Otras medidas consultar



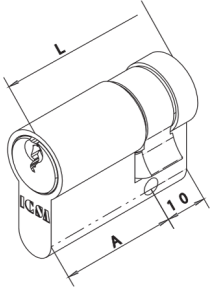

LEVA LARGA 15mm.

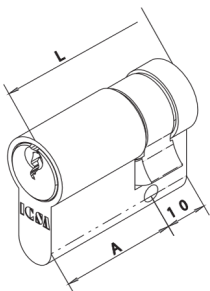

L mm	A mm	B mm	COD. LATON	COD. NIQUEL		
37	27	10	0075271013-	0075271023-	1	20
40	30	10	0075301013-	0075301023-	1	20
45	35	10	0075351013-	0075351023-	1	20
50	40	10	0075401013-	0075401023-	1	20
55	45	10	0075451013-	0075451023-	1	20
60	50	10	0075501013-	0075501023-	1	20
65	55	10	0075551013-	0075551023-	1	20
70	60	10	0075601013-	0075601023-	1	20
75	65	10	0075651013-	0075651023-	1	20
80	70	10	0075701013-	0075701023-	1	20
85	75	10	0075751013-	0075751023-	1	20
90	80	10	0075801013-	0075801023-	1	20
95	85	10	0075851013-	0075851023-	1	20
100	90	10	0075901013-	0075901023-	1	20
105	95	10	0075951013-	0075951023-	1	20
110	100	10	00751001013-	00751001023-	1	20

LEVA CORTA 13mm.



L mm	A mm	B mm	COD. LATON	COD. NIQUEL		
37	27	10	0075271012-	0075271022-	1	20
40	30	10	0075301012-	0075301022-	1	20
45	35	10	0075351012-	0075351022-	1	20
50	40	10	0075401012-	0075401022-	1	20
55	45	10	0075451012-	0075451022-	1	20
60	50	10	0075501012-	0075501022-	1	20
65	55	10	0075551012-	0075551022-	1	20
70	60	10	0075601012-	0075601022-	1	20
75	65	10	0075651012-	0075651022-	1	20
80	70	10	0075701012-	0075701022-	1	20
85	75	10	0075751012-	0075751022-	1	20
90	80	10	0075801012-	0075801022-	1	20
95	85	10	0075851012-	0075851022-	1	20
100	90	10	0075901012-	0075901022-	1	20
105	95	10	0075951012-	0075951022-	1	20
110	100	10	00751001012-	00751001022-	1	20

Otras medidas consultar

CILINDRO OVALADO

Cilindro Ovalado



MOD C4



ES

- CARACTERÍSTICAS TÉCNICAS:**
- Cuerpo de latón
 - Rotores de latón
 - Leva tonda sinterizado autolubrificante
 - Leva DIN sobresalientes 30° de acero sinterizado autolubrificante sobre pedido
 - 5 Pernos de latón
 - Contrapernos de latón
 - Muelles de acero inoxidable
- LLAVES:**
- De latón niquelado



- NORMAS:**
- Conforme a la norma EN 1303:2005
 - Durabilidad : grado 5
 - 30.000 cifrados

- DOTACIÓN:**
- 3 llaves
 - Tornillo de fijación 5MAx50
- ACABADOS:**
- Latón
 - Latón niquelado satinado
 - Latón niquel brillo
 - Acabados especiales bajo

pedido

MOD C4 ART. 180
DOBLE CILINDRO OVALADO



	L mm	A mm	B mm	COD. LATON	COD. NIQUEL		
LEVA REDONDA	54	27	27	0180272710-	0180272720-	1	100
	60	27	33	0180273310-	0180273320-	1	20
	70	30	40	0180304010-	0180304020-	1	20

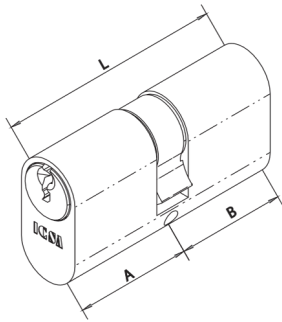

Altre misure a richiesta
Other dimensions on request
Otras medida bajo pedido
Autres mesures à la demande

MOD C4 ART. 90
MEDIO CILINDRO OVALADO

	L mm	A mm	B mm	COD. LATON	COD. NIQUEL		
LEVA REDONDA	54	27	10	0090271010-	0090271020-	1	100

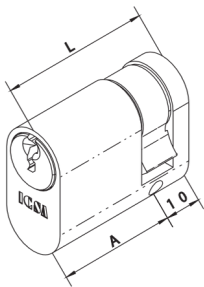

Otras medidas consultar



ART. C5MK

Maletin de Piezas para Igualamiento y Amaestramientos

Adaptables para modelos:

C5



ART. C6MK

Maletin de Piezas para Igualamiento y Amaestramientos

Adaptables para modelos:

C6-S2-S3-S5-S6-S7-S8



ART. S10MK

Maletin de Piezas para Igualamiento y Amaestramientos

Adaptables para modelos:

S10

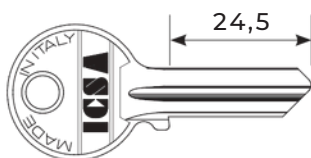

ART. 200

Adaptable para modelos:
C5 - 4 perni/pins/pitones/goujons

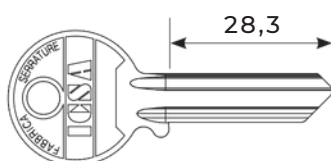

ART. 201

Adaptable para modelos:
C5 - C6

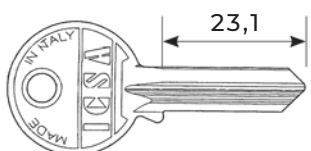

ART. 202

Adaptable para modelos:
C4

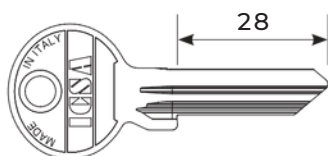

ART. 217

Adaptable para modelos:
S2 - S3

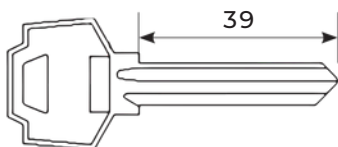

ART. 218

Adaptable para modelos:
ART. 260/263

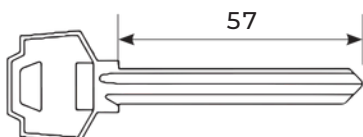

ART. 219

Adaptable para modelos:
ART. 260/263

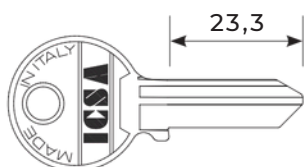

ART. 206

Adaptable para modelos:
S32 - S33

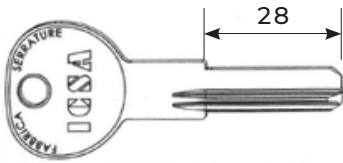

ART. 0625

Adaptable para modelos:
S6 - 10

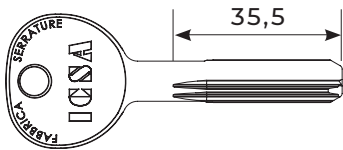

ART. 0627

Adaptable para modelos:
ART. HS6/I

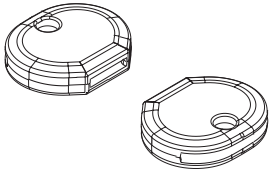

ART. 207

Adaptable para modelos:
S6 - 10

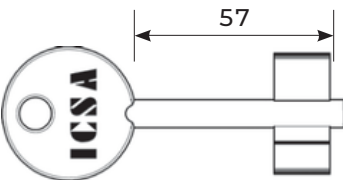

ART. 205

Adaptable para modelos:
DM320

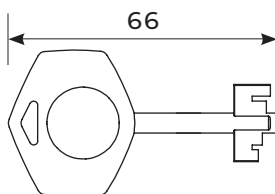

ART. 860

Adaptable para modelos:
ART. 704 - 710 - 705

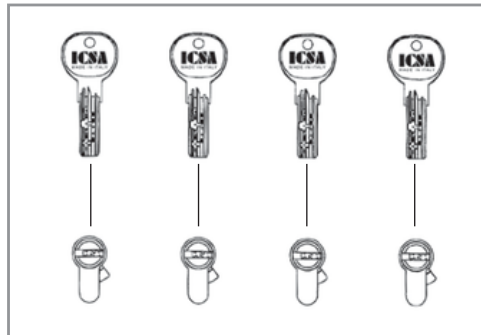

KD:
LLAVES
DIFERENTES

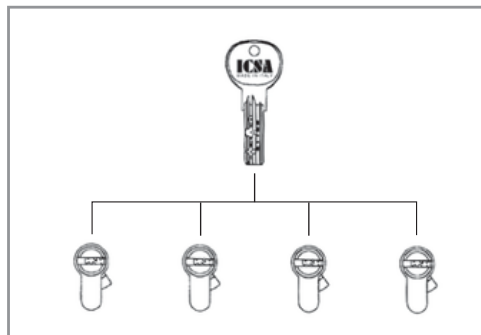

KA:
MISMA LLAVE

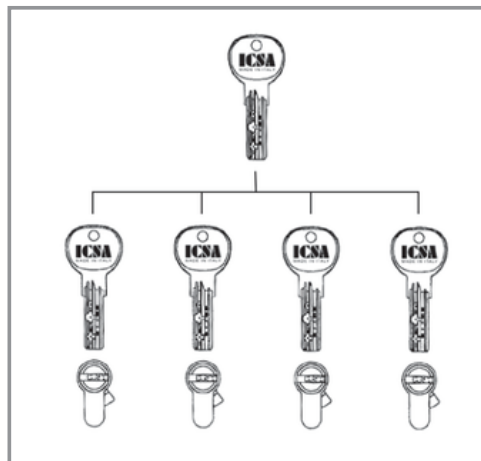

MK:
LLAVE MASTER

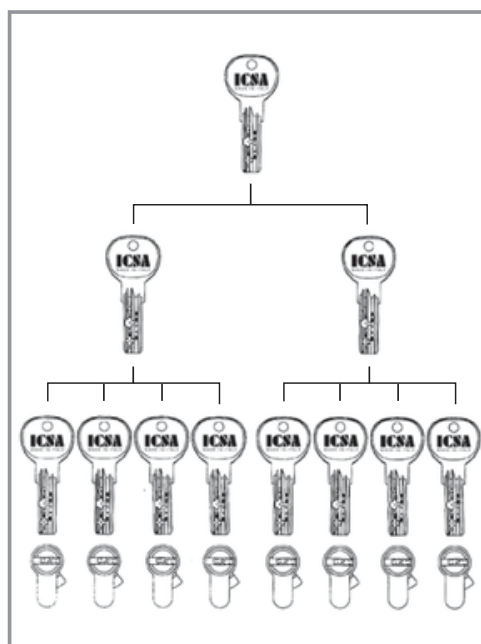

GMK:
LLAVE GRAN MASTER

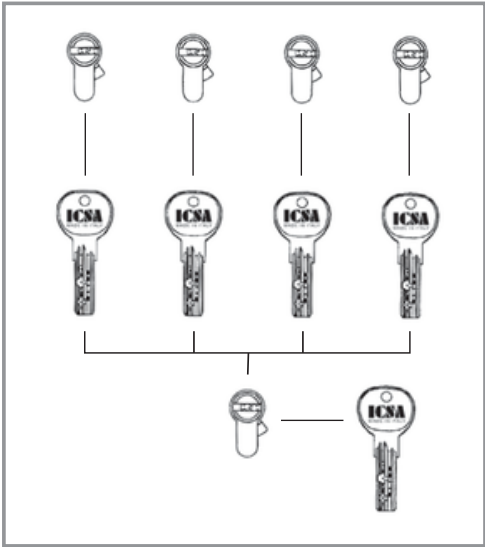

CK:
LLAVES
DIFERENTES

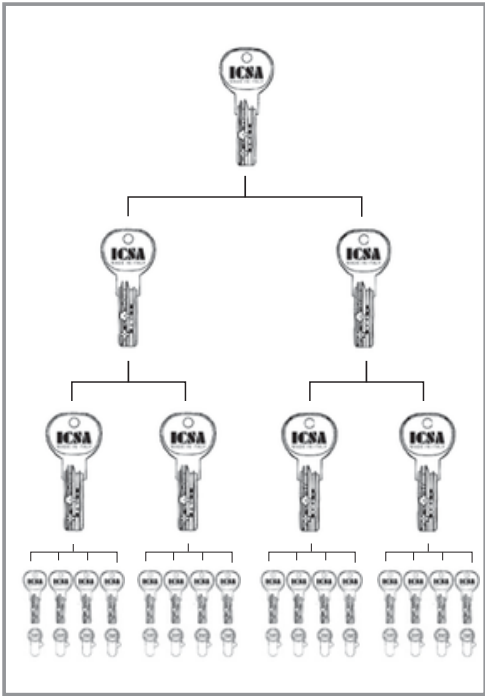

GGMK:
LLAVES
DIFERENTES



CARPINTERIA METALICA

info@sebalcab.es



MOD L18-1118/118

ES

CARACTERÍSTICAS TÉCNICAS:

- Caja de acero galvanizado
- Palanca basculante niquelada
- Picaporte ajustable y reversible niquelado
- Frente PLANO o "U"
- 3 Palancas laterales basculantes
- Palanca basculante individual art. 118

DOTACIÓN:

- Tornillos de fijación de la cerradura

ACABADOS:

- Acero inoxidable AISI 304
- Aluminio anodizado U art. 118

BAJO PEDIDO:

- Cerraderos específicos
- Bocallaves de nylon negro





FRENTE PLANO
FRENTE INOX.

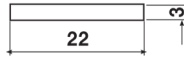

D mm
85
85

E mm
30
35

COD.
1118L30-
1118L35-

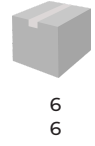

FRENTE U
FRENTE INOX.

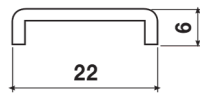

D mm
85
85

E mm
30
35

COD.
1118S30-
1118S35-

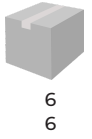
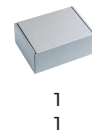



FRENTE CROMADO

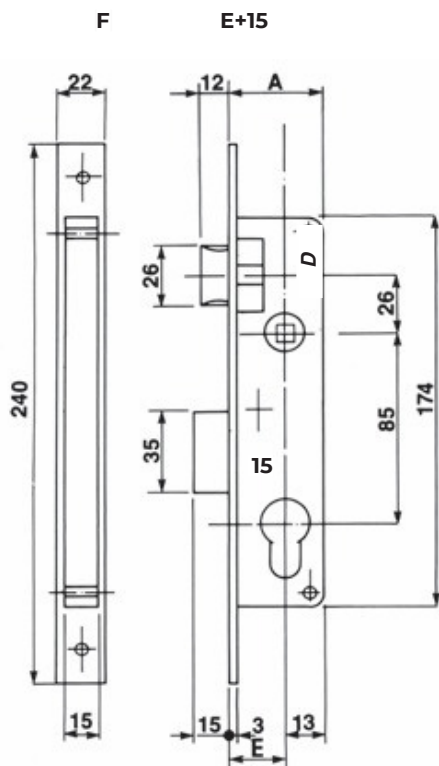

D mm	E mm	F mm
85	20	22
85	25	22
85	30	22
85	35	22

COD.
0102E20-
0102E25-
0102E30-
0102E35-

Box 1	Box 2
1	25
1	25
1	25
1	25

FRENTE ACERO INOXIDABLE

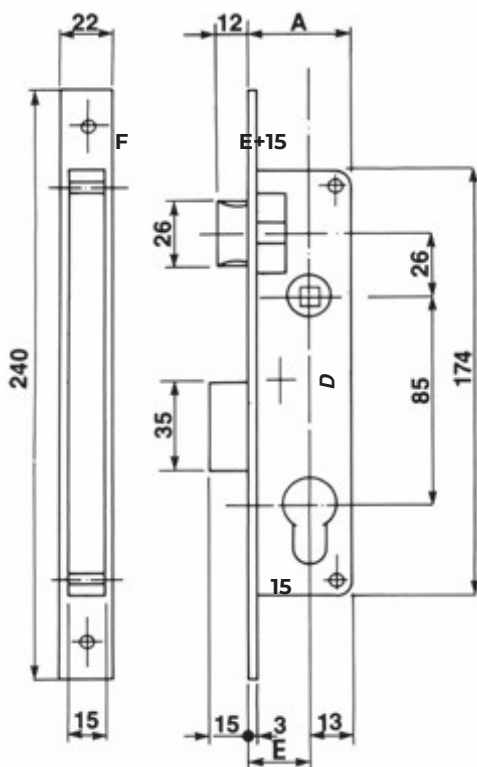

D mm	E mm	F mm
85	20	22
85	25	22
85	30	22
85	35	22

COD.
0102I20-
0102I25-
0102I30-
0102I35-

Box 1	Box 2
1	25
1	25
1	25
1	25





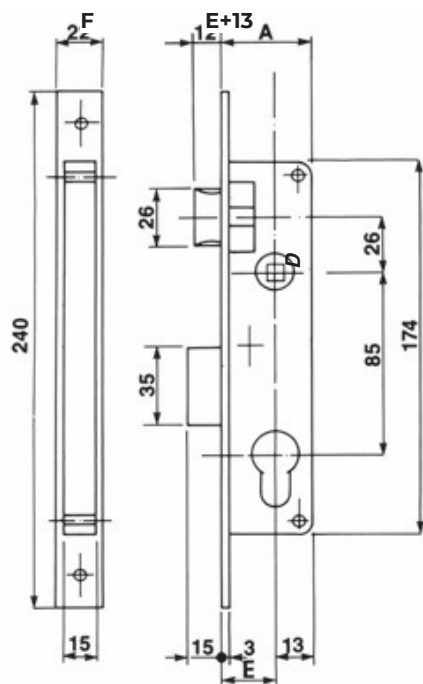

FRENTE CROMADO
FUNCIONA CON LEVA CORTA



<i>D</i> mm	<i>E</i> mm	<i>F</i> mm
85	23	22
85	28	22
85	33	22
85	38	22

COD.
0103E23-
0103E28-
0103E33-
0103E38-



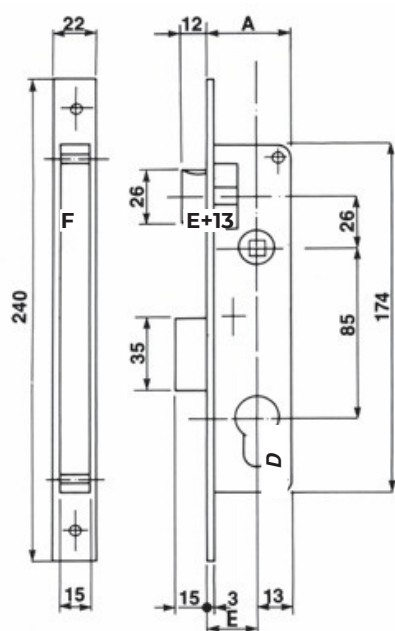

	1	25
	1	25
	1	25
	1	25

FRENTE ACERO INOX.
FUNCIONA CON LEVA CORTA



<i>D</i> mm	<i>E</i> mm	<i>F</i> mm
85	23	24
85	28	24
85	33	24
85	38	24

COD.
0103L23-
0103L28-
0103L33-
0103L38-

	1	25
	1	25
	1	25
	1	25



FRENTE CROMADO
FUNCIONA CON LEVA CORTA

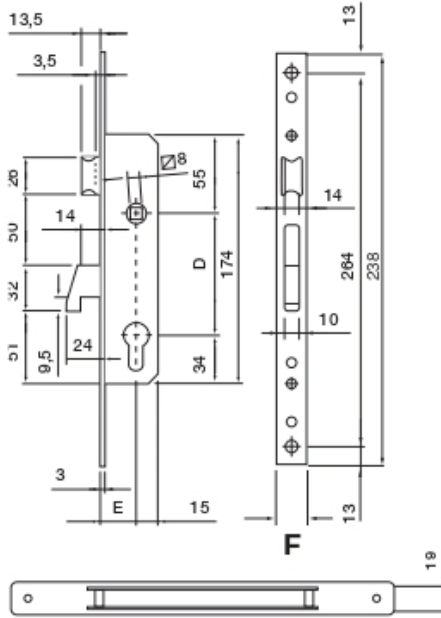

<i>D mm</i>	<i>E mm</i>	<i>F mm</i>
85	25	24

COD.
0101225-

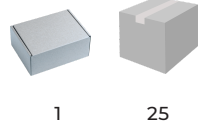



FRETE CROMO
FUNCIONA CON LEVA LARGA

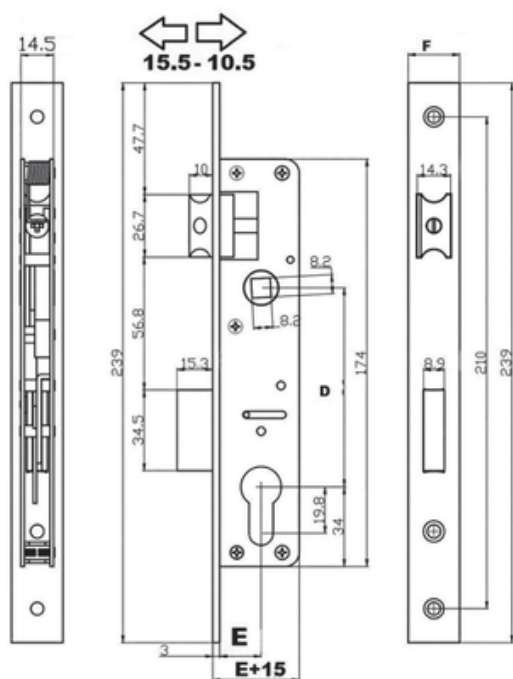

D mm	E mm	F mm
85	20	23
85	25	23
85	30	23
85	35	23

COD.

R107E20-
R107E25-
R107E30-
R107E35-

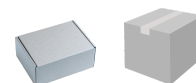

1	25
1	25
1	25
1	25

FRENTE INOX
FUNCIONA CON LEVA LARGA

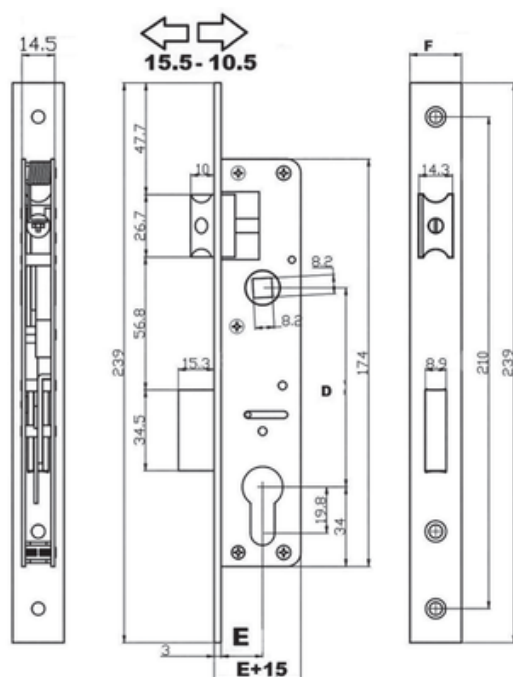

D mm	E mm	F mm
85	20	23
85	25	23
85	30	23
85	35	23

COD.

R107I20-
R107I25-
R107I30-
R107I35-

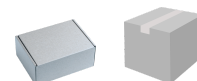

1	25
1	25
1	25
1	25



CROMADA



D mm	E mm	F mm
72	30	25
72	40	25
72	50	25
72	60	25

COD.

- 0112R30-
- 0112R40-
- 0112R50-
- 0112R60-

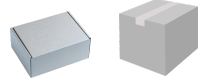

- | | |
|---|----|
| 1 | 20 |
| 1 | 20 |
| 1 | 20 |
| 1 | 20 |

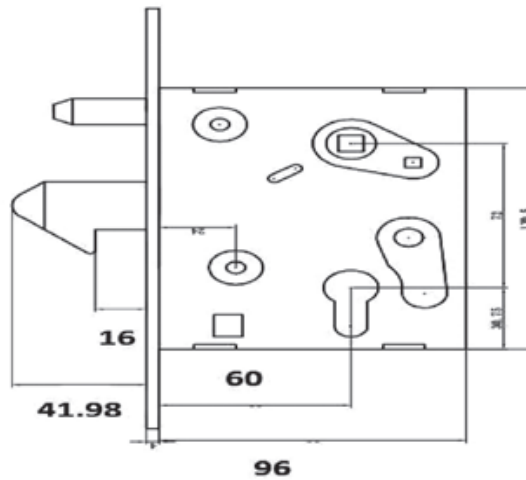
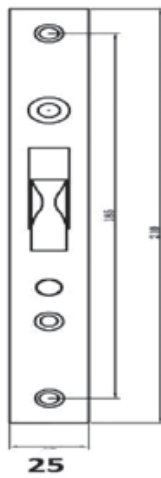



Embalaje en bolsa de nylon

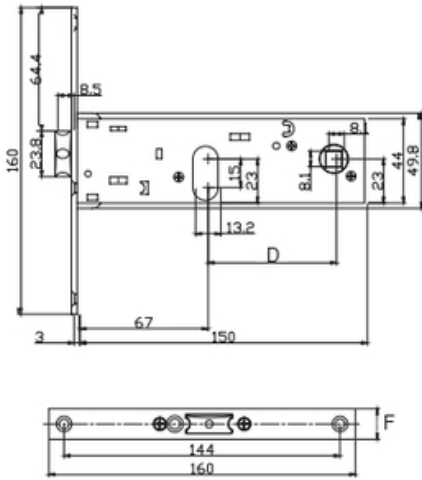

D mm	E mm	F mm
67	70	16
67	70	20
67	80	16
67	80	20

COD.

0402T70...N-
0402N70...N-
0402T80...N-
0402N80...N-

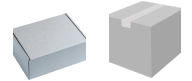

1	20
1	20
1	20
1	20

MOD **L7** ART. **404**
 CERRADURA CARPINTERIA METALICA

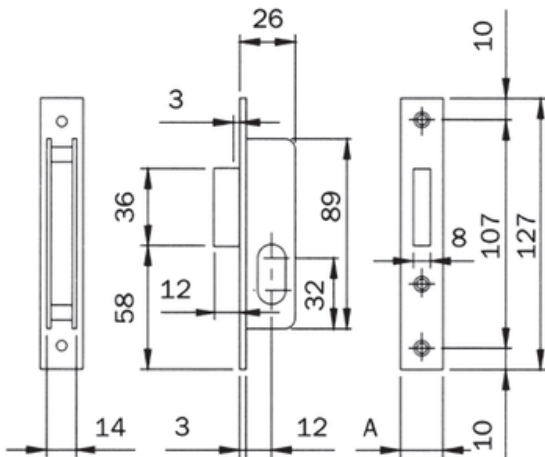

E mm	F mm
15	20

COD.

0404N15-

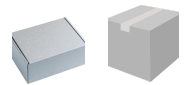

1	25
---	----



Embalaje en caja individual

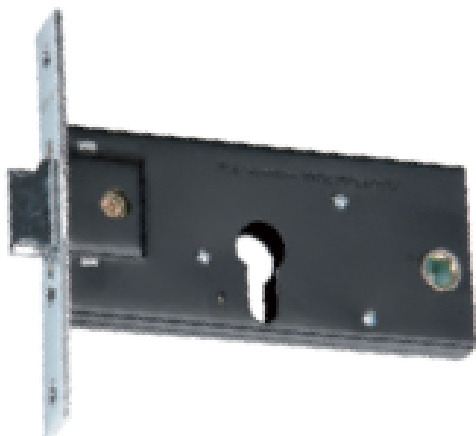

D mm	E mm	F mm
65	60	16
65	70	20

COD.
0406F60-
0406F70-

Box 1	Box 2
1	20
1	20

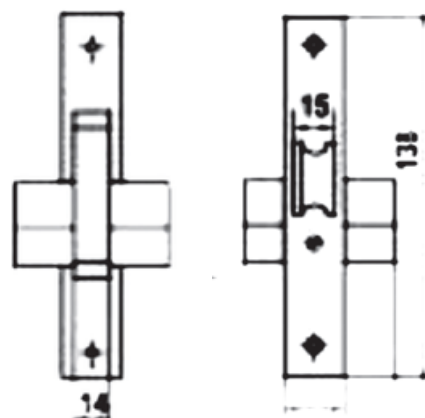
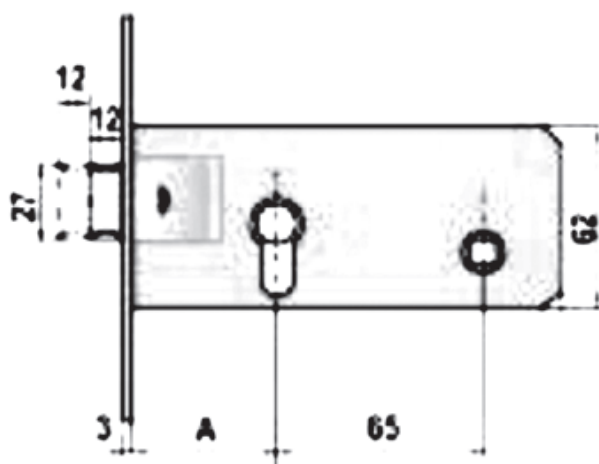



**FRENTE INOX
SOLO PICAPORTE**

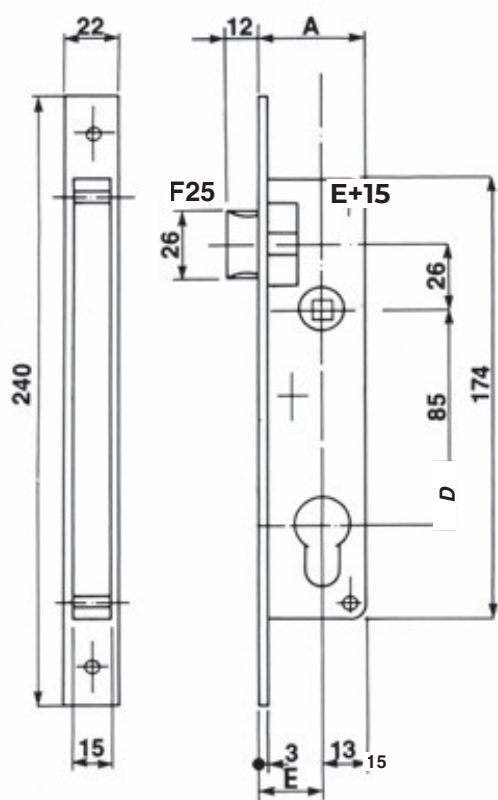

<i>D</i> mm	<i>E</i> mm	<i>F</i> mm
85	20	22
85	25	22
85	30	22
85	35	22

COD.

**0104E20-
0104E25-
0104E30-
0104E35-**

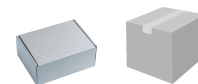

1	25
1	25
1	25
1	25

**FRENTE INOX
SOLO PASTILLA**

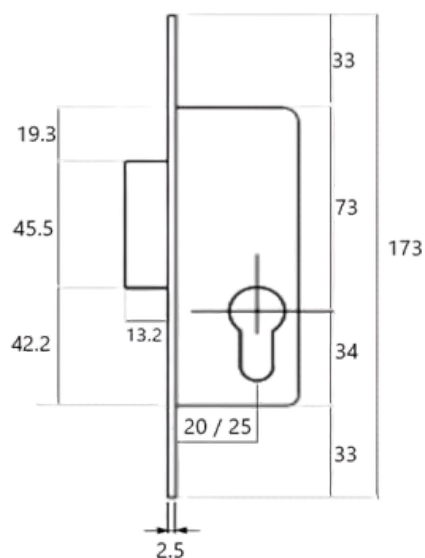

<i>E</i> mm	<i>F</i> mm
20	22
25	22
30	22
35	22

COD.

**0124E20-
0124E25-
0124E30-
0124E35-**

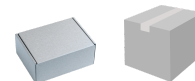

1	25
1	25
1	25
1	25

MOD **L16** ART. **116**
 CERRADURA CORTAFUEGO 72mm CANTO CUADRADO



FRENTE ACERO INOX.
 CERTIFICADA AL FUEGO

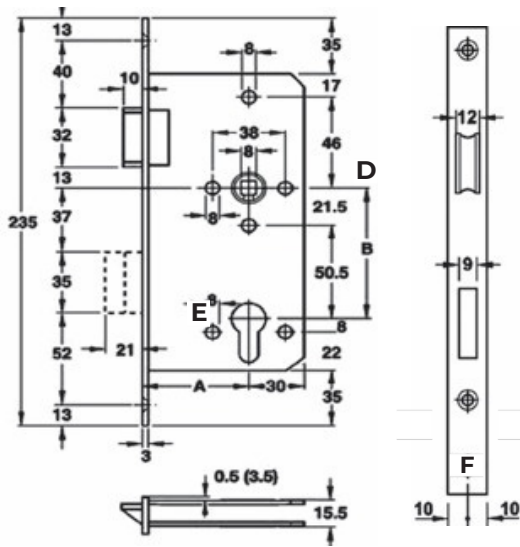

D mm	E mm	F mm	COD.		
72	55	24	0116L55-	1	25
72	55	20	0116&55-	1	25

MOD **L16** ART. **126**
 CERRADURA CORTAFUEGO 72mm CANTO REDONDO

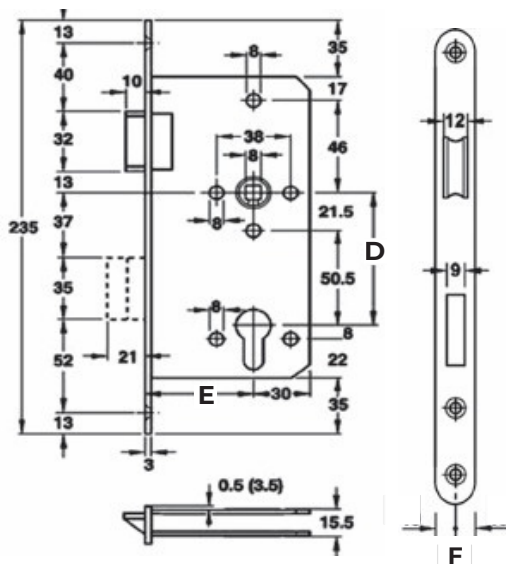

D mm	E mm	F mm	COD.		
72	55	24	0126L55-	1	25
72	55	20	0126&55-	1	25

MOD L8 ART. 1738/1739
 SERRATUREMULTIUSO - MULTI-PURPOSELOCKS
 CERRADURASMULTIUSO - SERRURESÀUSAGEMÚLTIPLE

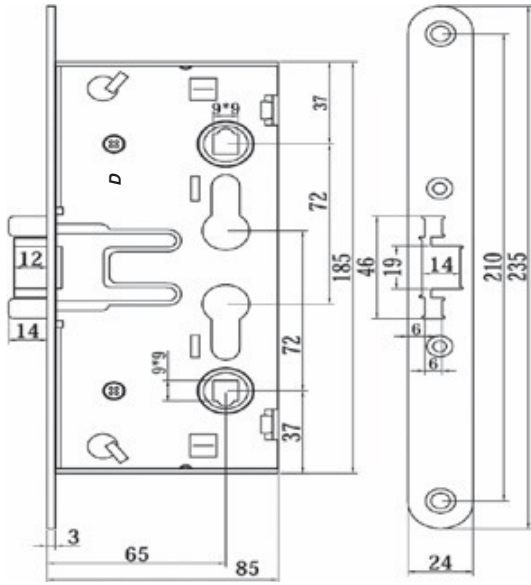

D mm
72

E mm
65

F mm
24

COD.
173872652-

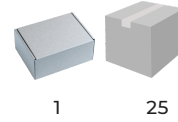

1

25

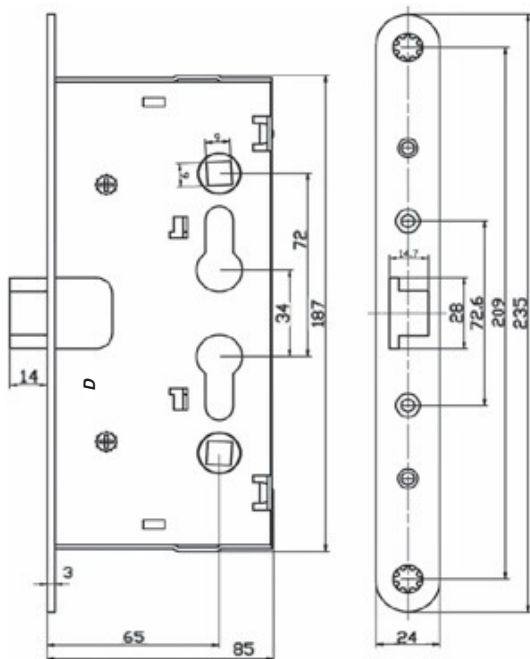

D mm
72

E mm
65

F mm
24

COD.
173972652-

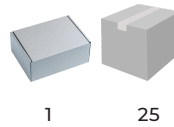

1

25



COD.
09190000-



1



20



COD.
09200000-



1



20

ACESORIOS

CERRADEROS PARA PUERTAS METALICAS



Adaptable para modelos:

102/102R/103/103R/104/105/107/96

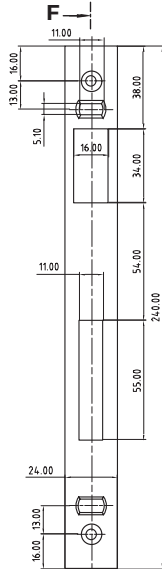

COD.	F mm	
37	22	200

ACERO INOX

102/102R/103/103R/104/105/107/96

37	24	200
----	----	-----

ACERO INOX

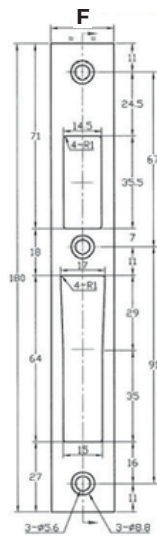

Adaptable para modelos:

101

COD.	F mm	
44	24	200

ACERO INOX

ACESORIOS

CERRADEROS PARA PUERTAS METALICAS

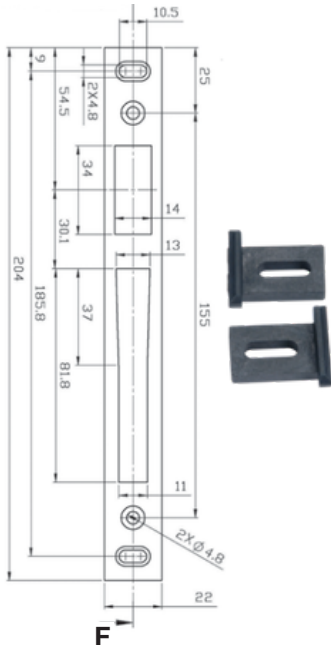

Adaptable para modelos:

**102/102R/103/103R/104/105/107/96/106/111/99/97/118
/1118/1119/122/1222/1223**

COD.	F mm	
53	22	200

ACERO INOX

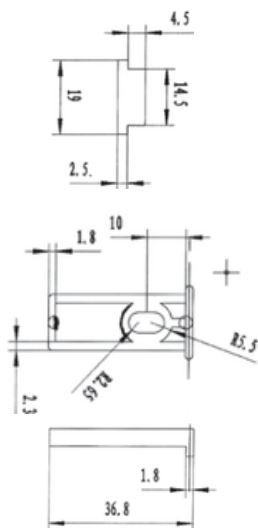

Adaptable para modelos:

**102/102R/103/103R/104/105/107/96/106/111/99/97/118
/1118/1119/122/1222/1223**

COD.	F mm	
53/A		1000

PLÁSTICO NEGRO

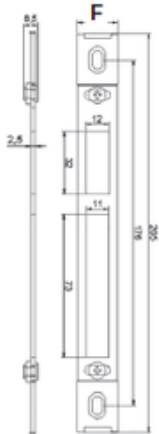

Adaptable para modelos:

118

COD.	F mm	
196	20	35
ACERO INOX		

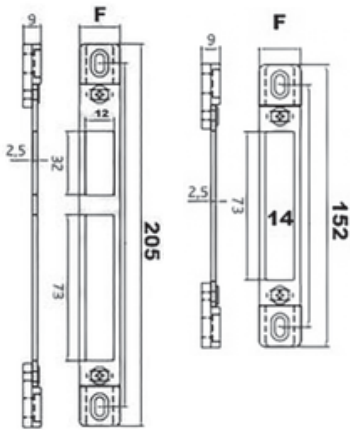

Adaptable para modelos:

L18

COD.	F mm	
197	20	35
ACERO INOX		

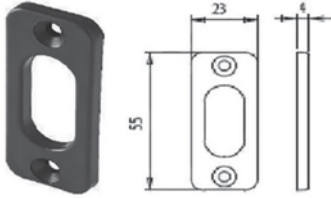

Adaptable para modelos:
402/401/410/404/403/407

COD.

F mm



46

1000

PLÁSTICO NEGRO



Adaptable para modelos:
**102/102R/103/103R/104/105/107/96/106/111/99/97/118
/1118/1119/122/1222/1223/121**

COD.

F mm



47

1000

PLÁSTICO NEGRO



CARPINTERIA MADERA

info@sebalcab.es



LATON

D mm
85

E mm
50

F mm
20

COD.
1134-Y50-

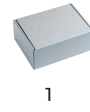

1

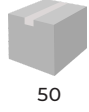

50

NIQUEL

D mm
85

E mm
50

F mm
20

COD.
1134-W50-

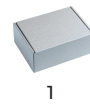

1

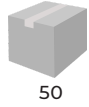

50

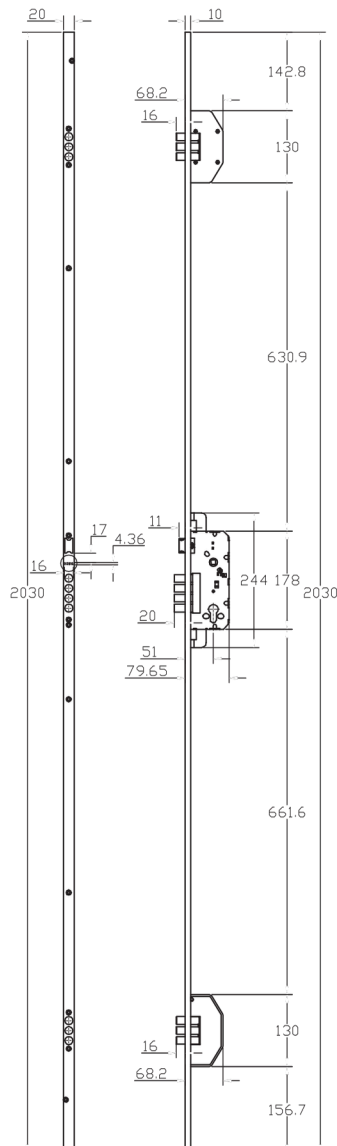

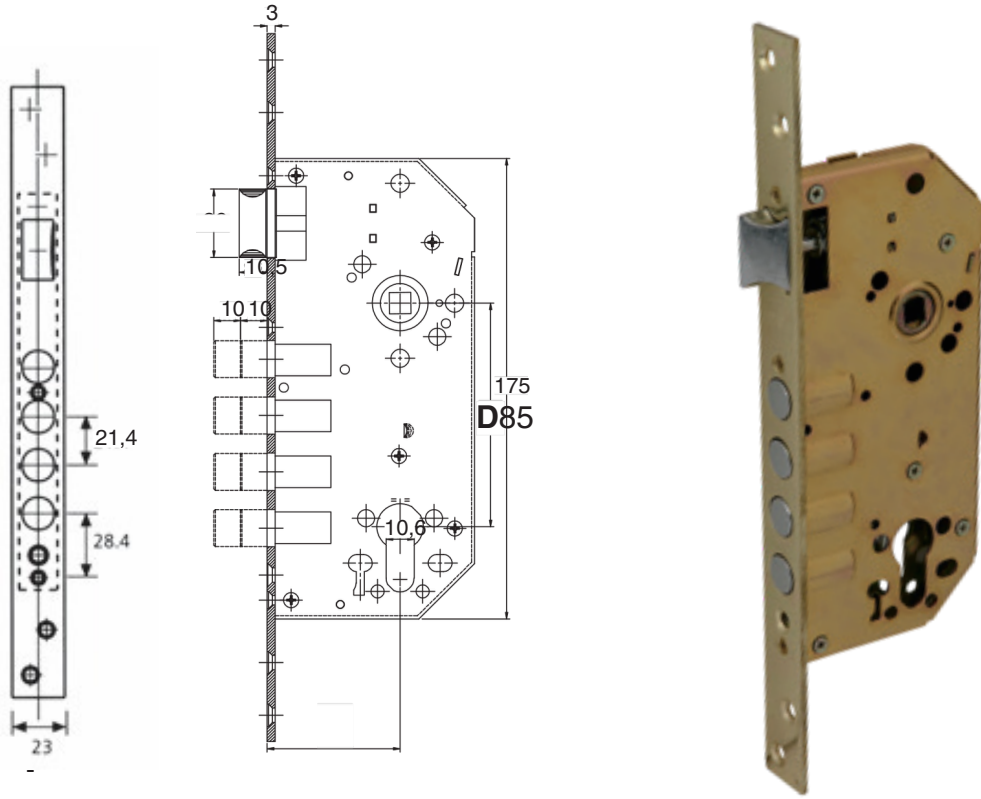

LATON

D mm

85

E mm

50

F mm

23

COD.

0134C50-



1



20

NIQUEL

D mm

85

E mm

50

F mm

23

COD.

0134F50-



1



20

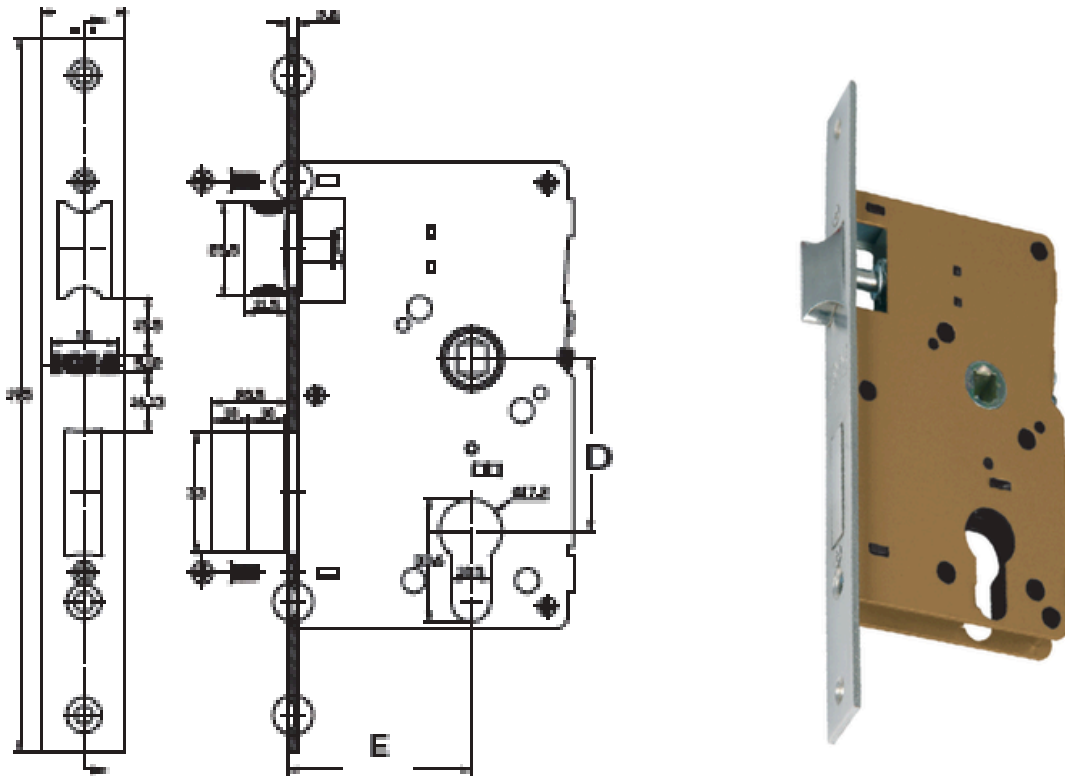

LATON BRILLO
 CANTO CUADRADO

D mm	E mm	F mm	COD.
47	40	22	0127D40-
47	50	22	0127D50-
47	60	22	0127D60-



1	25
1	25
1	25

MOD L15 ART. 129
 CERRADURA MADERA 47mm. CANTO REDONDO

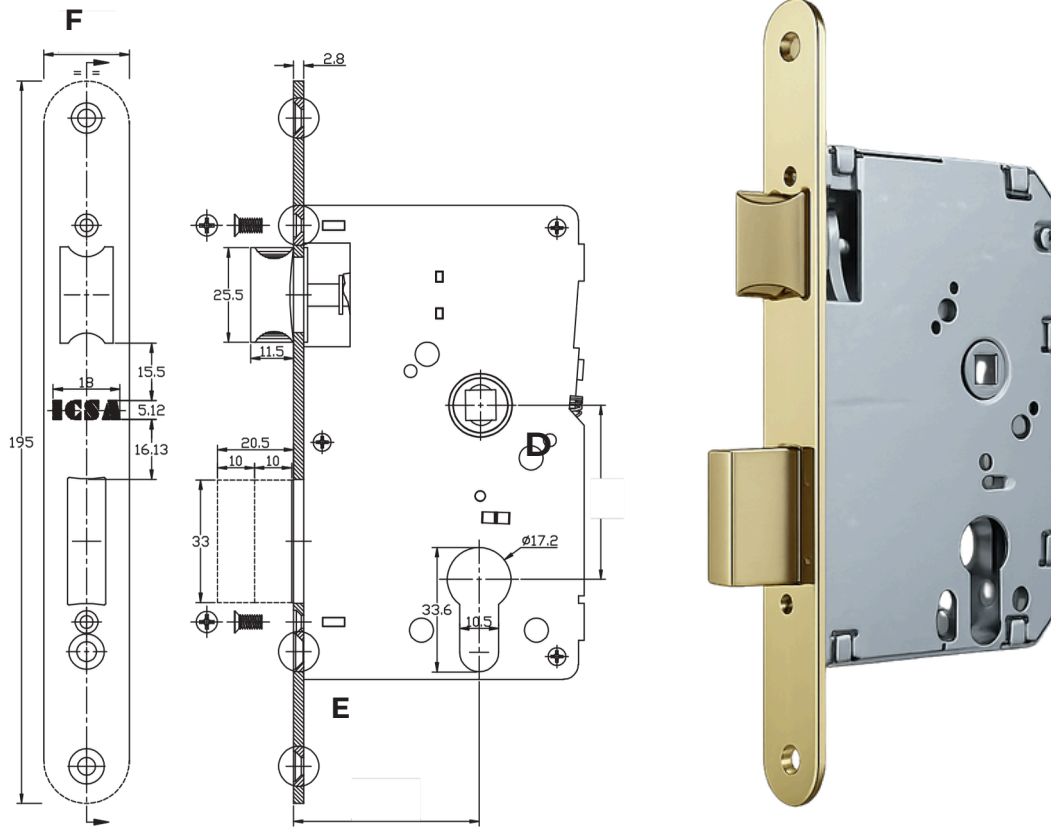

**LATON BRILLO
 CANTO REDONDO**



D mm	E mm	F mm	COD.
47	40	22	0129D40-
47	50	22	0129D50-
47	60	22	0129D60-

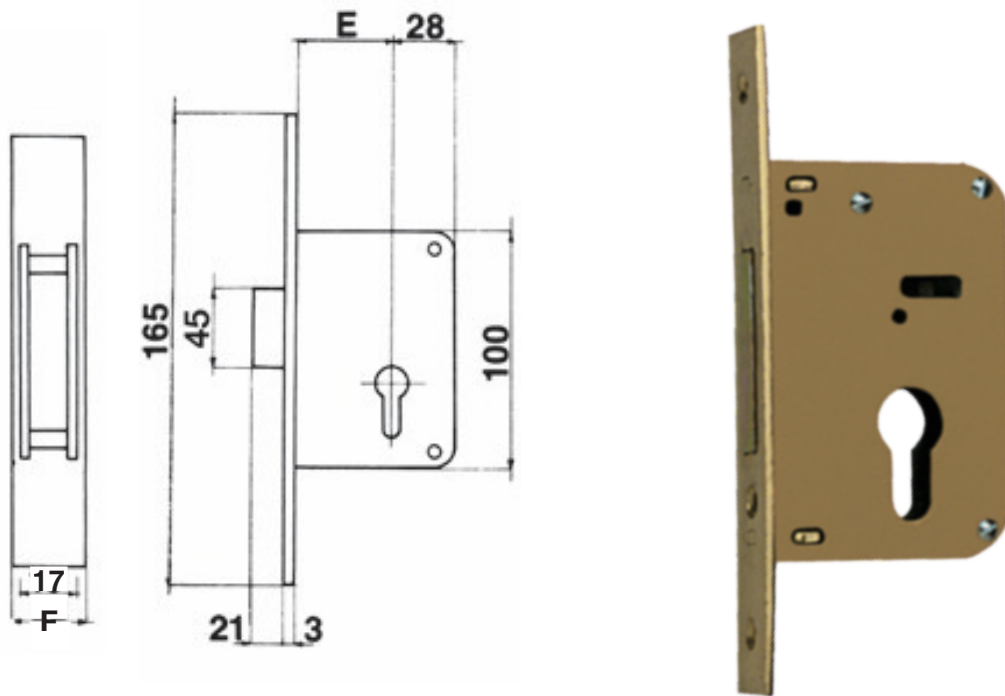

1	25
1	25
1	25



LATON SATINADO

E mm	F mm	COD.		
30	22	0130C40-	1	25
35	22	0130C45-	1	25
40	22	0130C50-	1	25
45	22	0130C45-	1	25
50	22	0130C50-	1	25
60	22	0130C60-	1	25





CERRADURAS SOBREPONER

info@sebalcab.es

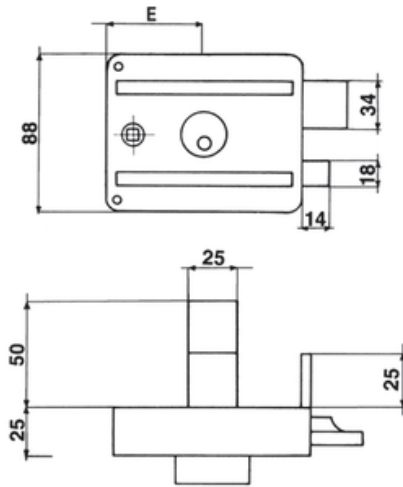

MOD **S21** ART. 280-281
CERRADURA SOBREPONER



	DERECHA	IZQUIERDA	E mm	DCF	DCS	COD.		
X X			60	X		028060-	1	6
			60		X	0280602-	1	6
X X			60	X		028160-	1	6
			60		X	0281602-	1	6

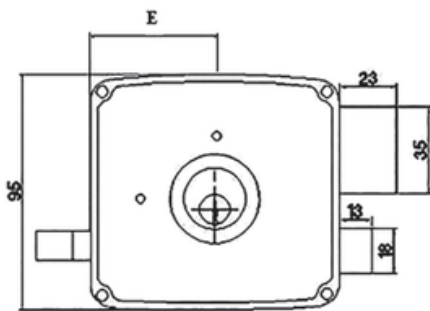

MOD **S21** ART. 1494-1495
CERRADURA SOLAPAR



	DERECHA	IZQUIERDA	E mm	DCF	DCS	COD.		
X X			40	X		149480-	1	30
			50	X		1494100-	1	30
X X			40	X		149580-	1	30
			50	X		1495100-	1	30

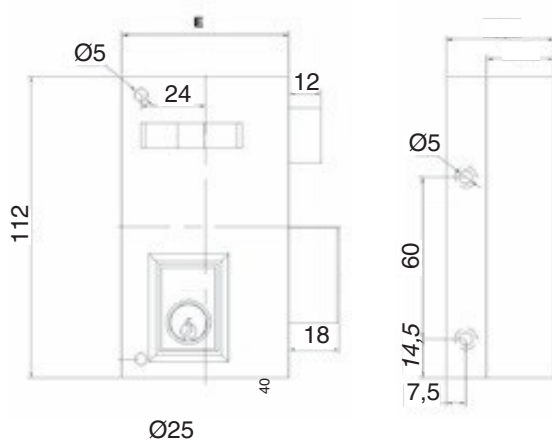

MOD **S56** ART. **56/A**
CERRADURA SOLAPAR

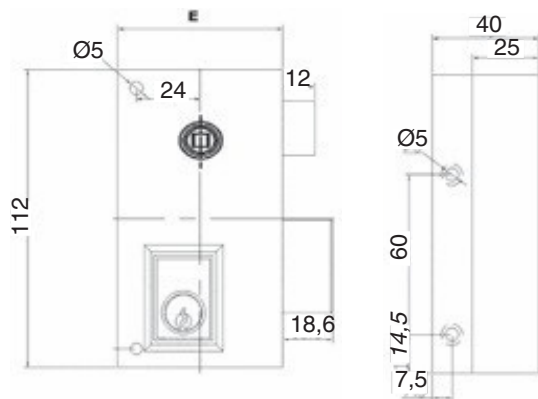

ART.	DERECHA	IZQUIERDA	E mm	COD.		
56/A/D	X		60	0056AD60-	1	20
56/A/S		X	60	0056AS60-	1	20
56/A/D	X		70	0056AD70-	1	20
56/A/S		X	70	0056AS70-	1	20

MOD **S56** ART. **56/B**
CERRADURA SOLAPAR



ART.	DERECHA	IZQUIERDA	E mm	COD.		
56/B/D	X		60	0056BD60-	1	20
56/B/S		X	60	0056BS60-	1	20
56/B/D	X		70	0056BD70-	1	20
56/B/S		X	70	0056BS70-	1	20

MOD **S26** ART. **260**
CERRADURA SOLAPAR

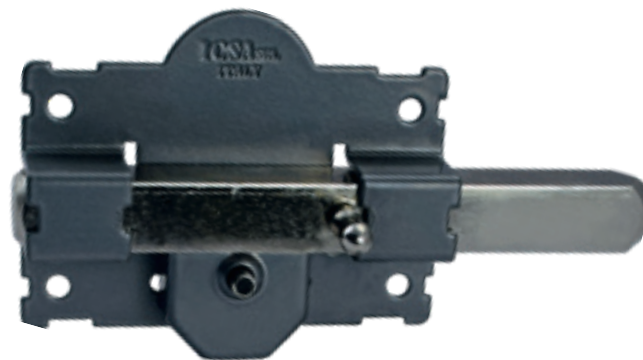
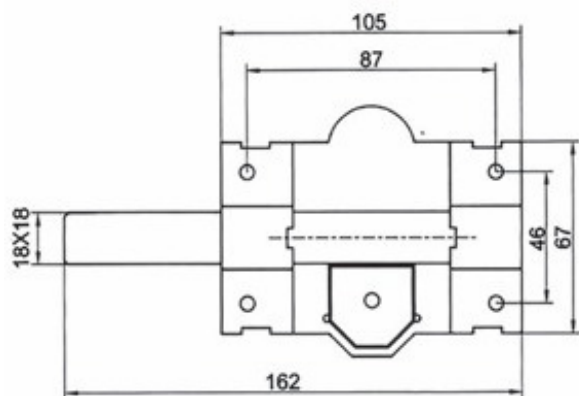

CILINDRO

50
70

COD.

026000500G-
026000700G-

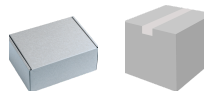

1 20
1 20

MOD **S26** ART. **263**
SERRATUREDAAPPLICARE-RIM LOCK

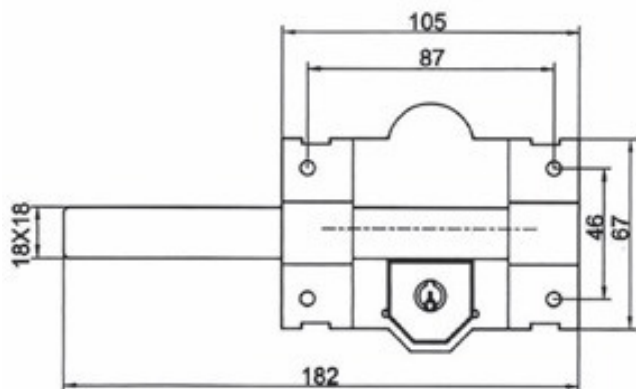

CILINDRO

50
70

COD.

026300500G-
026300700G-

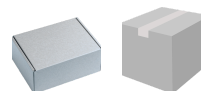

1 20
1 20

MOD **S70** ART. **704**
 CERRADURA ALTA SEGURIDAD SOBREPONER

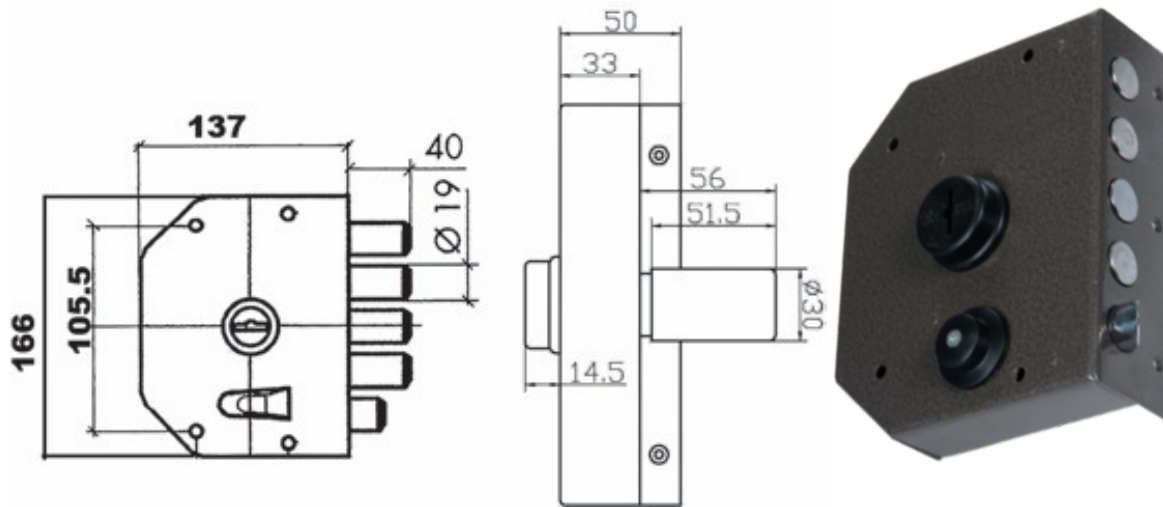

× DERECHA
 IZQUIERDA

COD.
 07045000-

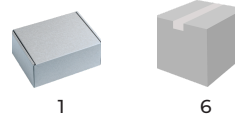

MOD **S70** ART. **710**
 CERRADURA ALTA SEGURIDAD SOBREPONER

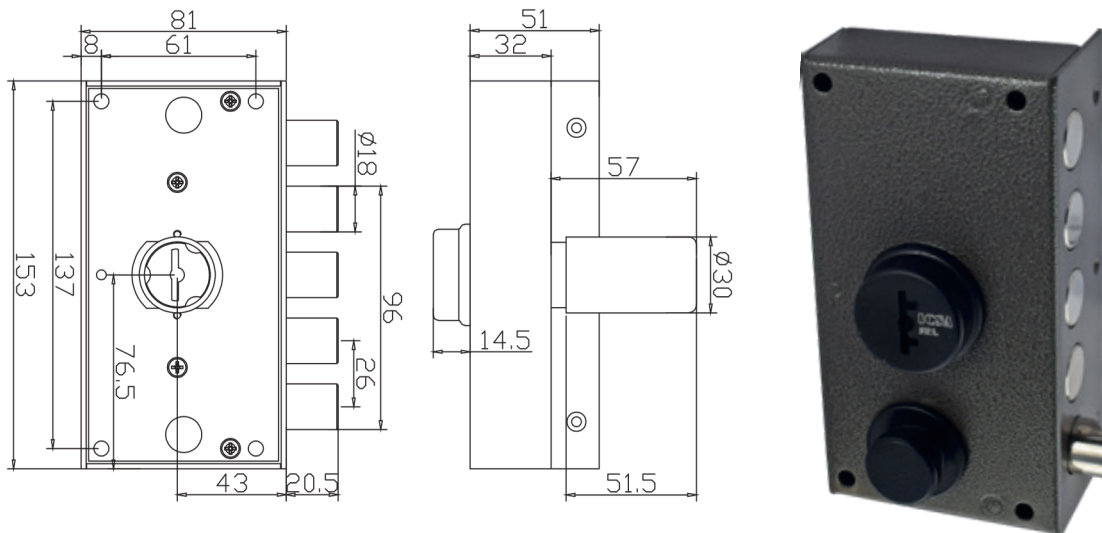

× DERECHA
 IZQUIERDA

COD.
 07105000-

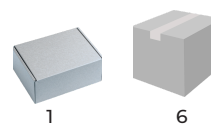

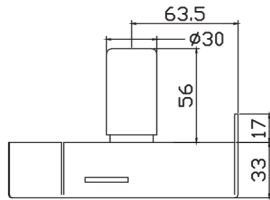
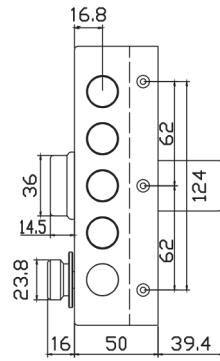
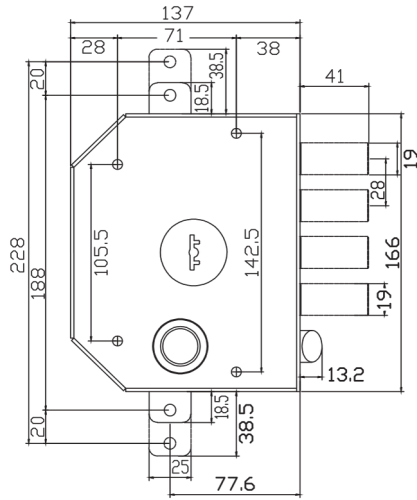

x x DERECHA

IZQUIERDA

BARRAS

x

COD.

07055000-
070550000C-



1
1



8
8

MOD **S32** ART. **320**
CERRADURA PERSIANA SOLAPADA

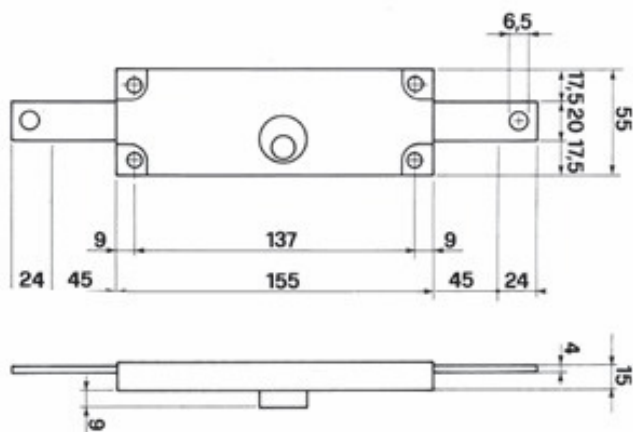

ART.	PERNIO	COD.		
320/9	X	032090002-	1	8

Disponible también en versión KA:

320/9/KA	X	0320900020A-	1	8
----------	---	--------------	---	---

MOD **S32** ART. **DM3320**
SERRATURE PERSERRANDE- LOCKSFORROLLINGSHUTTERS
CERRADURA PARAPERSIANAS ENROLLABLES - SERRURE DE VOLETS ROULANTS

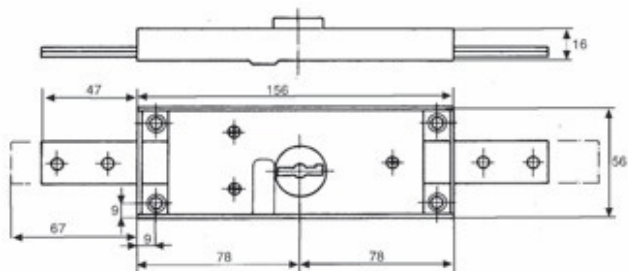

ART.	PERNIO	COD.		
DM320/9	X	332090002-	1	25



CERRADURA GARAJE

info@sebalcab.es



MOD E70



CARACTERÍSTICAS TÉCNICAS:

- Caja, cerradero y placa protectora de acero pintado gris aluminio
- Entrada 50/60/70/80 mm.
- A JUSTABLE
- Abertura interior • Picaporte de bloqueo automático • Tensión 12 V ca • Electricidad absorbida 2,5A • Cilindro y botón interiores, cilindro exterior (art. 2770)
- Cilindro exterior y interior (art. 2170)

- Dispositivo de parada interior (art. 2770)
- Botón en ABS
- Mano derecha o izquierda
- Intercambiables con la mayoría de las cerraduras existentes
- Cilindro exterior de 5 pernos
- Cuerpo y rotores de latón
- Muelles internas de los cilindros de bronce

NORMAS:

- Conforme a la norma prEN 14 846:08:
 - Grado 3 de Seguridad (500 Kg. empuje lateral y 200 Kg. carga delantera)

DOTACIÓN:

- 3 Llaves de latón niquelado
- Tornillos de fijación
- Cerradero
- Placa Protectora
- Bocallave
- Hoja de instrucciones

MOD **E70** ART. **2770**
CERRADURA ELECTRICA REGULABLE

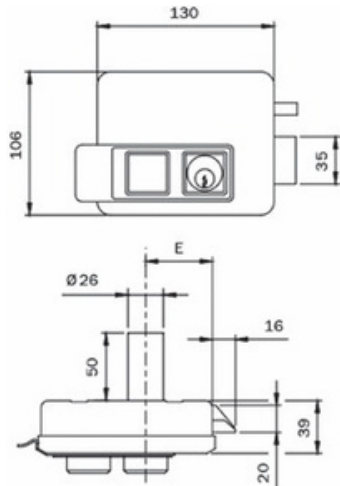

DOBLE CILINDRO REGULABLE



x DERECHA

x IZQUIERDA

DCF
x
x

COD.
2770000000-
2770002000-

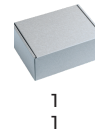

MOD **E70** ART. **2170**
CERRADURA ELECTRICA REGULABLE

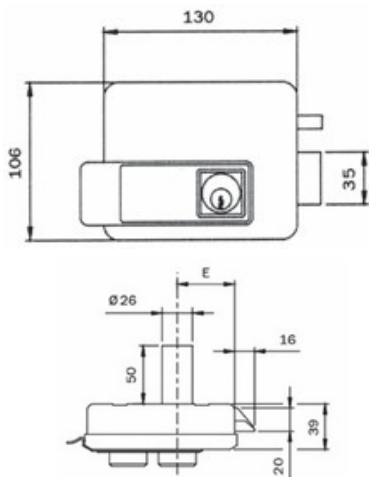

x DERECHA

x IZQUIERDA

E mm
50/60/70/80
50/60/70/80

COD.
21700000-
217000200-

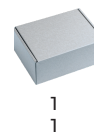



MOD E76 - EVO



CARACTERÍSTICAS TÉCNICAS:

- Caja, cerradero, placa protectora y placa pequeña de acero pintado negro
- Palanca 2 vueltas manuales
- Entrada ajustable 50/60/70/80 mm.
- Abertura interior
- Picaporte de bloqueo automático
- Tensión 12 V ca
- Electricidad absorbida 2,5A
- Cilindro y botón interiores, cilindro exterior art. 2776
- Cilindro exterior y interior art. 2176

- Botón en ABS
- Placa de cubierta del botón en ABS
- Mano derecha o izquierda
- Intercambiables con la mayoría de las cerraduras existentes
- Cilindro exterior de 5 pernos
- Cuerpo y rotores de latón
- Muelles internas de los cilindros de bronce

NORMAS:

- Conforme a la norma prEN 14846:08: 3C200L302
- Grado 3 de Seguridad (500 Kg. empuje lateral y 200 Kg. carga delantera)

DOTACIÓN:

- 3 Llaves de latón niquelado
- Tornillos de fijación
- Cerradero
- Placa Protectora
- Bocallave
- Placa de cubierta del botón en ABS
- Hoja de instrucciones

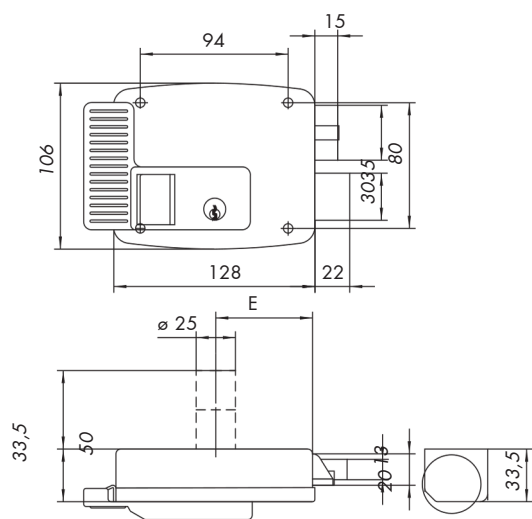

E=60



x DERECHA

IZQUIERDA

E mm

50/60/70/80
 50/60/70/80

COD.

2881DB1-
 2881SB1-



1
 1



8
 8

KIT PROLONGACIONE E70-E76

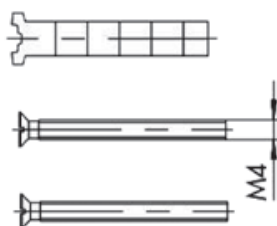
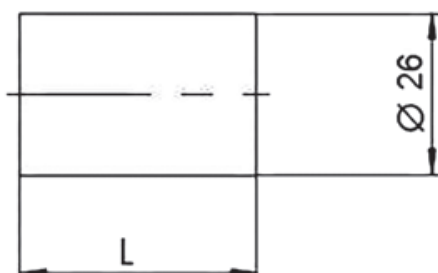

COD.
 173



20



CIERRAPUERTAS

info@sebalcab.es



MOD DC6

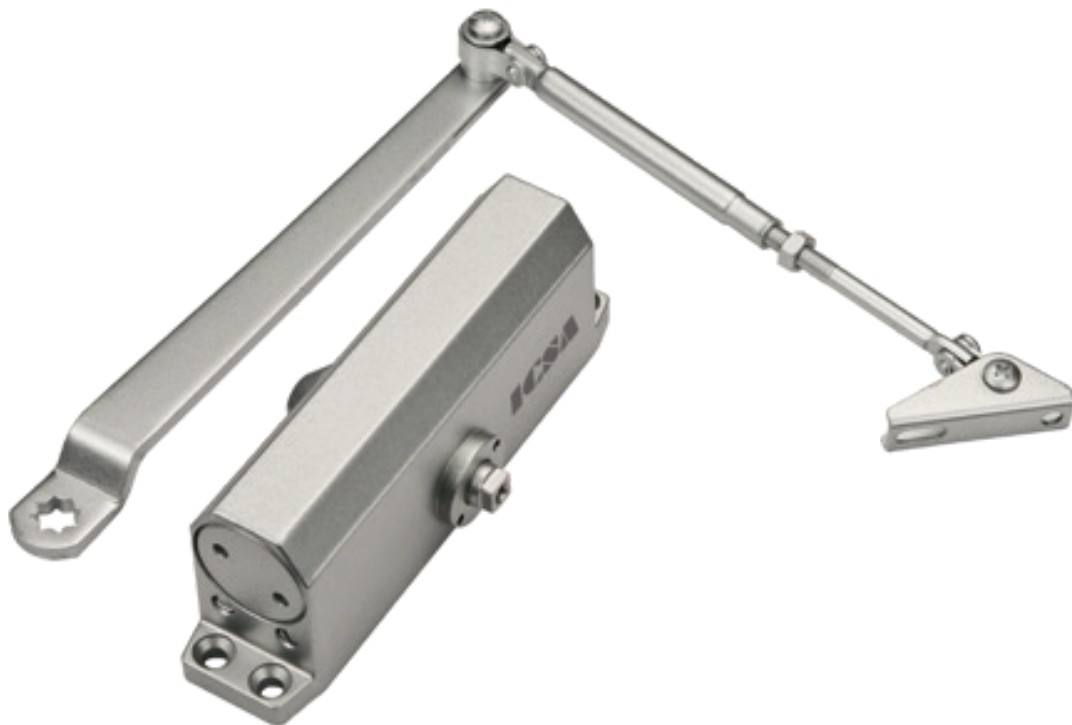

CARACTERÍSTICAS TÉCNICAS:

- Cuerpo monobloque de zamak
- Brazo de acero
- Muella de acero especial a baño de lubricante
- Válvulas de regulación independientes con dispositivo termostático
- Válvula de sobrecarga
- Puertas hasta 65kg y 900 mm.
- Dispositivo de parada integrado bajo pregunta (art. 603) en el cuerpo

ACCIONAMIENTO:

- Fuerza de cierre 2
- Velocidad de cierre de 180° a 15° actuando sobre la válvula adecuada
- Potencia de impacto final de 15° a 0° actuando sobre la válvula adecuada

NORMATIVAS:

• MOD DC6 ART. 600
BRAZO SALIENTE
483113

• MOD DC6 ART. 600

BRAZO Y TRAVESAÑO
PARALELOS
383113

DOTACIÓN:

- Tornillo de fijación
 - Tapa
 - Instrucciones de montaje
- ACABADOS:
- Plata
 - Negro
 - Blanco
 - Acabados especiales bajo pedido

MOD DC6 ART. 600
CIERRAPUERTA

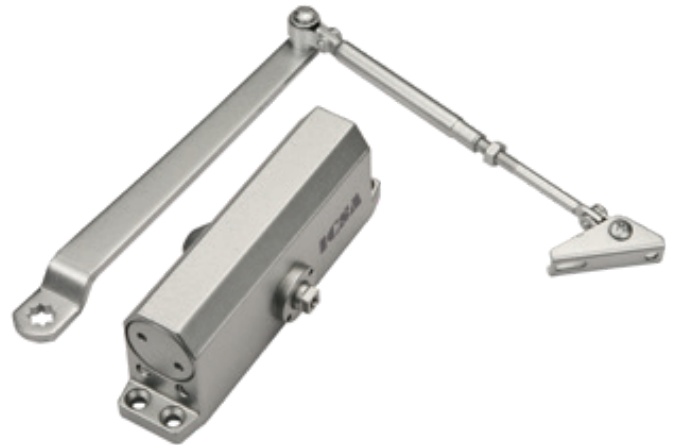
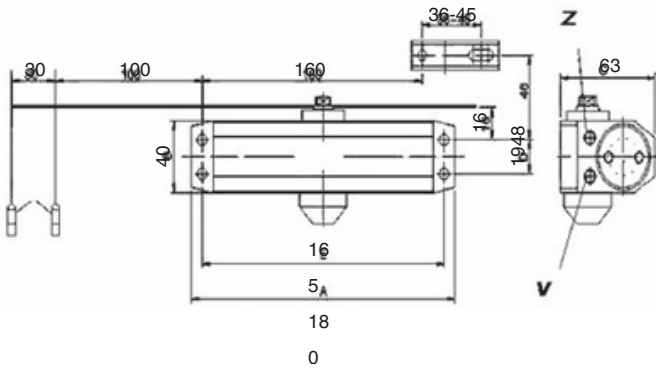

ART.	KG.	MM. MAX	RETEN	COLOR	COD.
600	40-65	900	SIN RETEN	PLATA	0600B00000-
600	40-65	900	SIN RETEN	NEGRO	0600E00000-
600	40-65	900	SIN RETEN	BLANCO	0600C00000-

MOD DC6 ART. 603
CIERRAPUERTAS

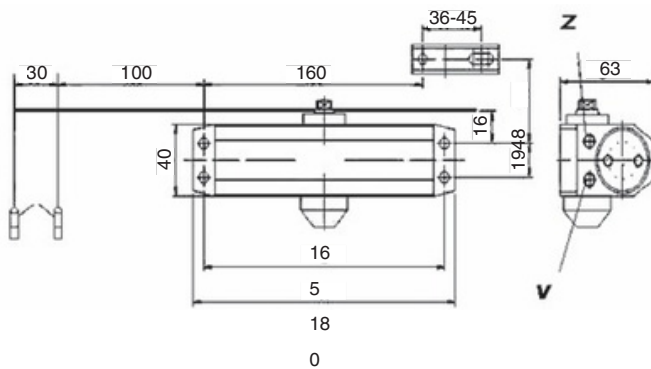

ART.	KG.	MM. MAX	RETEN	COLOR	COD.
603	40-65	900	CON RETEN	PLATA	0603B00000-
603	40-65	900	CON RETEN	NEGRO	0603E00000-
603	40-65	900	CON RETEN	BLANCO	0603C00000-

MOD DC6 ART. 610
CIERRAPUERTAS

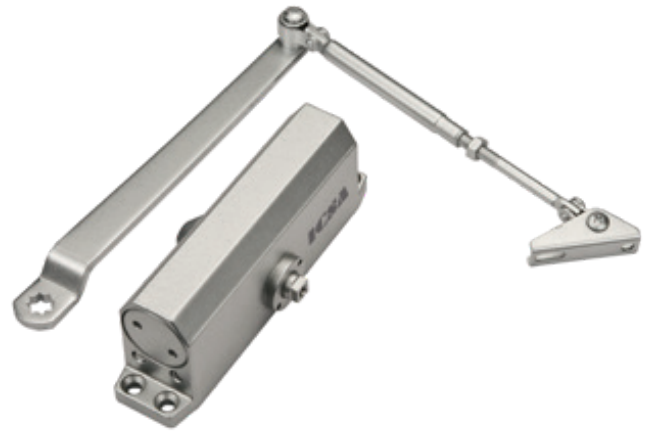
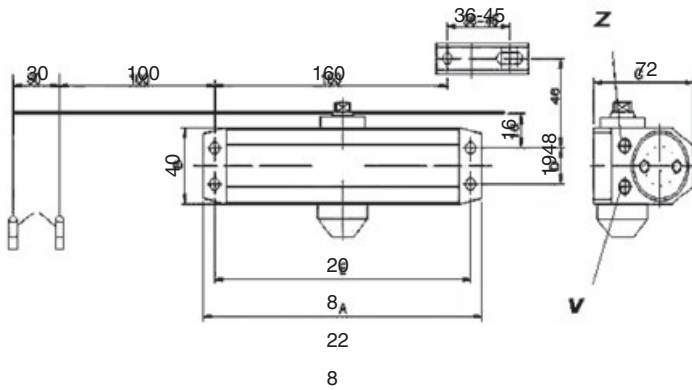

ART.	KG.	MM. MAX	RETEN	COLOR	COD.
610	60-85	1050	SIN RETEN	PLATA	0610B00000-

MOD DC6 ART. 611
CHIUDIPIORTA- DOORCLOSER
CIERRAPUERTA -FERME-PORTE

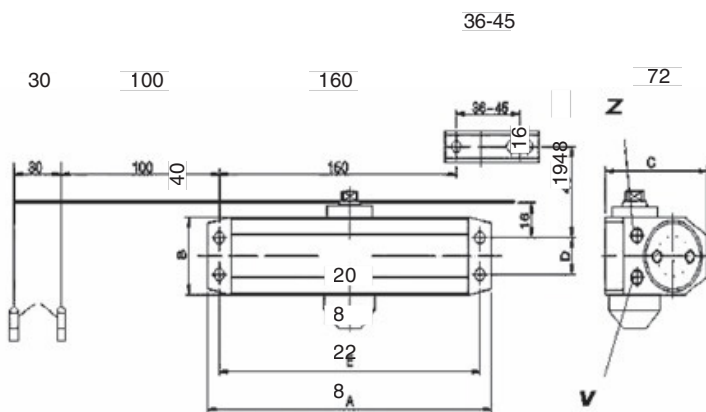

ART.	KG.	MM. MAX	RETEN	COLOR	COD.
611	60-85	1050	CON RETEN	PLATA - ARGENT	0611B00000-

MOD DC6 ART. 620
CIERRAPUERTAS

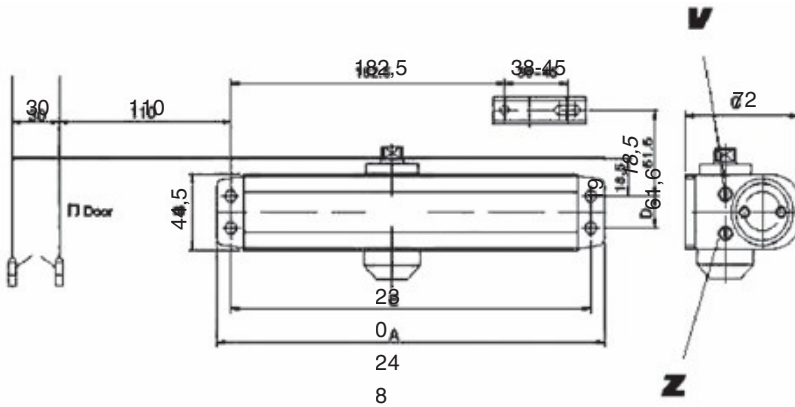

ART.	KG.	MM. MAX	RETEN	COLOR	COD.
620	80-120	1200	SIN RETEN	PLATA	0620B00000-

MOD DC6 ART. 621
CHIUDIPIORTA- DOORCLOSER
CIERRAPUERTA -FERME-PORTE

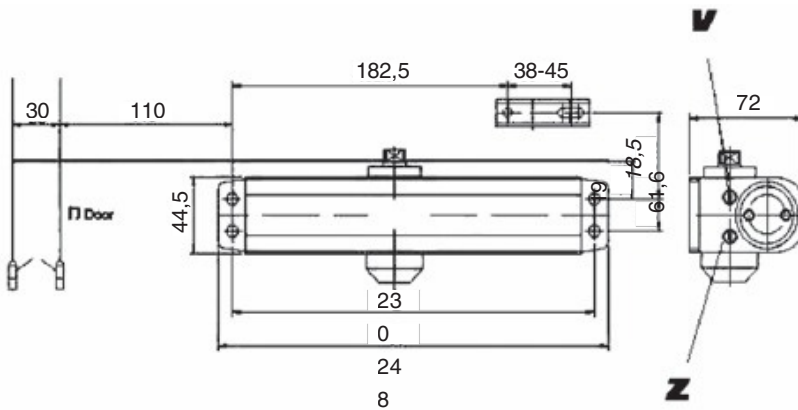

ART.	KG.	MM. MAX	RETEN	COLOR	COD.
621	80-120	1200	RETEN EN EL BRAZO	PLATA	0621B00000-

MOD DC8 ART. 608
CIERRAPUERTAS

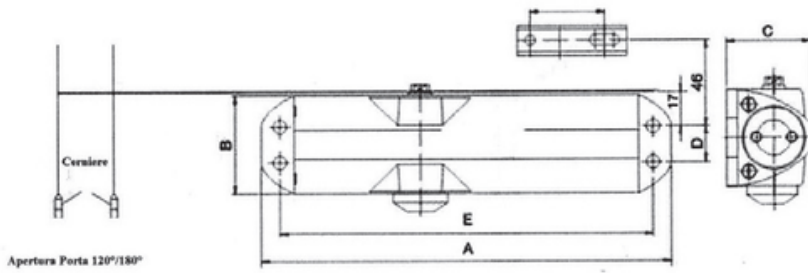

ART.	KG.	MM. MAX	FUNCIÓN	COLOR	COD.
608		1100	ESTÁNDAR	PLATA	0608B00000-
608		1100	ESTÁNDAR	NEGRO	0608E00000-
608		1100	ESTÁNDAR	BLANCO	0608C00000-

MOD DC8 ART. B608
CIERRAPUERTASD



ART.	KG.	MM. MAX	FUNCIÓN	COLOR	COD.
B608		1100	ESTÁNDAR	PLATA	0B608B0000-
B608		1100	ESTÁNDAR	NEGRO	0B608E0000-
B608		1100	ESTÁNDAR	BLANCO	0B608C0000-



ART.	KG.	MM. MAX	FUNCIÓN	COLOR	COD.
B609		1100	CON RETEN	PLATA	0B609B00000-
B609		1100	CON RETEN	NEGRO	0B609E00000-
B609		1100	CON RETEN	BLANCO	0B609C00000-



ANTIPANICOS

info@sebalcab.es



MOD A4



CARACTERÍSTICAS TÉCNICAS:

- Reversible
- Componible
- Perfectamente intercambiable con otro tipos de montante
- Picaporte de acero
- Capuchones de acero pintado
- 12V. AC-DC - 1A ART. A401/TEL

NORMATIVAS:

- Conforme a la norma EN 1125:2008 377B1422AA

- Art. 401/TEL: 377O1422AA

DOTACIÓN:

- Cerradero A490/5
- Tornillos
- Hoja de instrucciones

ACABADOS:

- Nero ral 9005
- Plata ral 7040
- Plata ral 9006
- Blanco ral 9010
- Pintura efecto acero inoxidable
- Cromo satinado
- Acabados especiales bajo pedido

MOD A4 ART. A401
ANTIPANICO UN PUNTO



1 PUNTO DE CIERRE

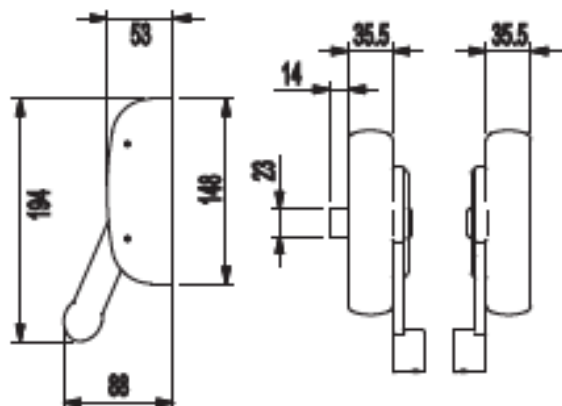

ART.	COLOR	
A401/T	NEGRO	1
A401/G	GRIS RAL 7040	1
A401/G6	GRIS RAL 9006	1
A401/B	BLANCO	1
A401/A	EFFECTO ACERO	1
A401/X	EFFECTO CROMADO	1

MOD A4 ART. A402
ANTIPANICO 2 PUNTOS

2 PUNTOS DE CIERRE

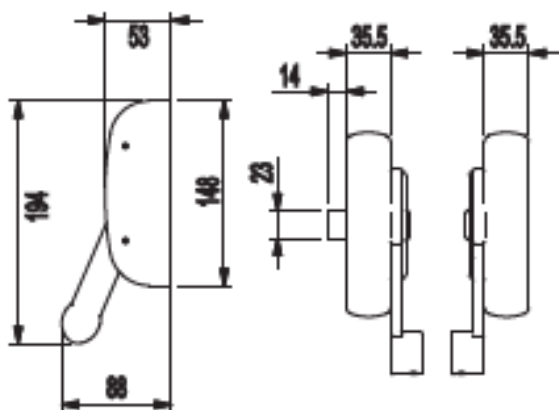

ART.	COLOR	
A402/T	NEGRO	1
A402/G	GRIS RAL 7040	1
A402/G6	GRIS RAL 9006	1
A402/B	BLANCO	1
A402/A	EFFECTO ACERO	1
A402/X	EFFECTO CROMADO	1

MOD **A4** ART. **A403**
ANTIPANICO TRES PIUNTOS DE CIERRE



MODULAR - 3 PUNTOS DE CIERRE
DISPONIBLE CON MECANISMO DE RETENCION

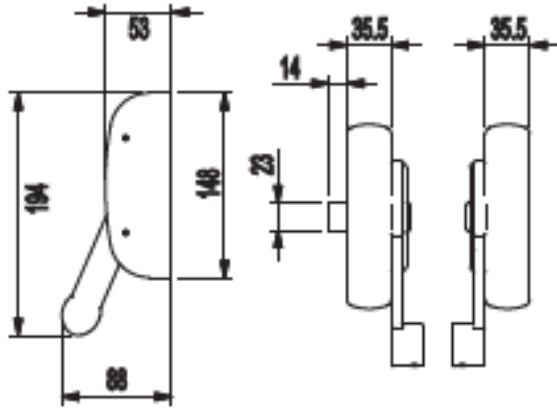

ART.
A403/T
A403/G
A403/G6
A403/B
A403/A
A403/X

COLOR
NEGRO
GRIS RAL 7040
GRIS RAL 9006
BLANCO
EFECTO ACERO
EFECTO CROMADO



1
1
1
1
1
1



MOD A5



FABRICANTE



JPM	SERIE 89	EN3000-EN3300-EN3400
ISEO	BASE E BASE BOLT	94011-94012-94015-94021-
CISA	PRESTIGE NEW EUROPA E FAST	94091 1.07077.46-1.07077.47-
SAVIO	BERNINI	1.07077.48 1.070778.28-1-07074.80 6000.870-6000.873-6000.875
VACHETTE	PREMIUM	6000.880-6000.876-6000.
TESA	UNIVERSAL	MMPS1-MMPS2-MMPS3-MMPP2

CARACTERÍSTICAS TÉCNICAS:

- Reversible
- Componible
- Perfectamente intercambiable con otro tipos de montante
- Picaporte de acero
- Capuchónes de acero pintado

NORMATIVAS:

- Conforme a la norma EN 1125:2008 377B1422AA

DOTACIÓN:

- Cerradero A490/5
- Tornillos
- Hoja de instrucciones

ACABADOS:

- Nero ral 9005
- Plata ral 7040
- Plata ral 9006
- Blanco ral 9010
- Pintura efecto acero inoxidable
- Cromo satinado
- Acabados especiales bajo pedido



1 PUNTO DE CIERRE

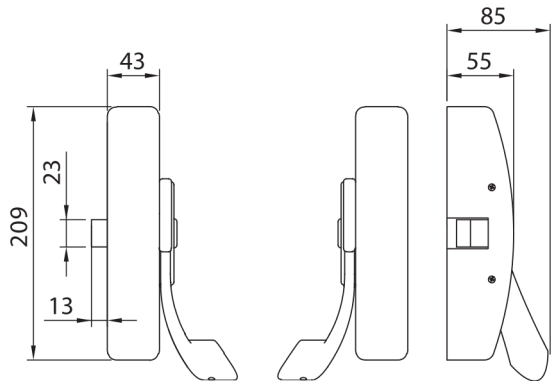

ART.	COLOR	
A501	NEGRO	1
A501/G	GRIS RAL 7040	1
A501/G6	GRIS RAL 9006	1
A501/B	BLANCO	1
A501/A	EFFECTO ACERO	1
A501/X	EFFECTO CROMADO	1

MOD A5 ART. A502
ANTIPANICO 2 PUNTOS

2 PUNTOS DE CIERRE

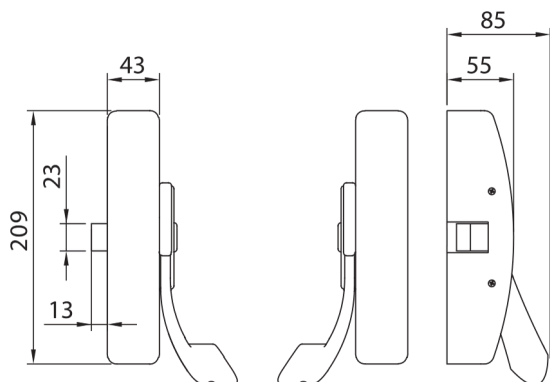

ART.	COLOR	
A502	NEGRO	1
A502/G	GRIS RAL 7040	1
A502/G6	GRIS RAL 9006	1
A502/B	BLANCO	1
A502/A	EFFECTO ACERO	1
A502/X	EFFECTO CROMADO	1

MOD **A5** ART. **A503**
ANTIPANICO TRES PIUNTOS DE CIERRE



MODULAR - 3 PUNTOS DE CIERRE
DISPONIBLE CON MECANISMO DE RETENCION

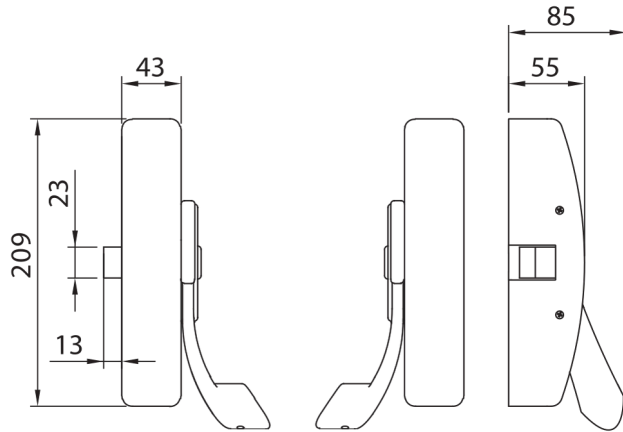

ART.
A503
A503/G
A503/G6
A503/B
A503/A
A503/X

COLOR
NEGRO
GRIS RAL 7040
GRIS RAL 9006
BLANCO
EFECTO ACERO
EFECTO CROMADO



1
1
1
1
1
1



MOD A6



CARACTERÍSTICAS TÉCNICAS:

- Reversible
- Componible
- Picaporte de acero
- Capuchones de acero pintado
- Cáster y barra de aluminio
- 12V. AC-DC - 1A. ART. A601/TEL
- 2-20V AC 1A, 12-30V DC 1º ART. A603/MOT

NORMATIVAS:

- Conforme a la norma EN 1125:2008 377B1422BA

- Art. A601/EL - Art. A601/MOT: 37701422BA

DOTACIÓN:

- Cerradero A490/5
- Tornillos
- Hoja de instrucciones

- ACABADOS: • Negro/Rojo ral 9005/3020 • Negro/Verde ral 9005/6029 • Negro/ Negro ral 9005/9005 • Plata/Plata ral 7040/7040 • Plata/Plata ral 9006/9006 • Blanco/Blanco ral 9010/9010 • Negro/Plata ral 9005/all.

- anodizado
- Pintura efecto acero inoxidable
- Cromo satinado
- Acabados especiales bajo pedido



1 PUNTO DE CIERRE

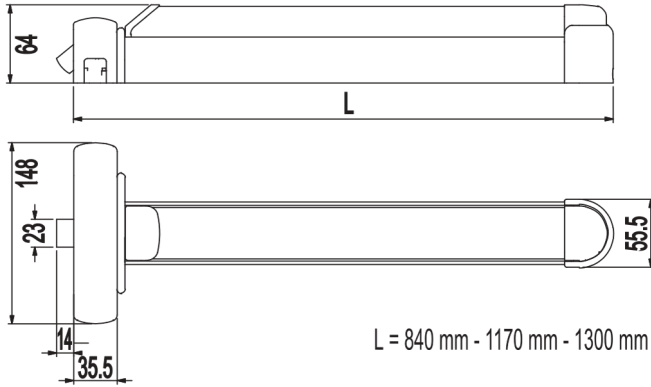

L = 840 mm - 1170 mm - 1300 mm

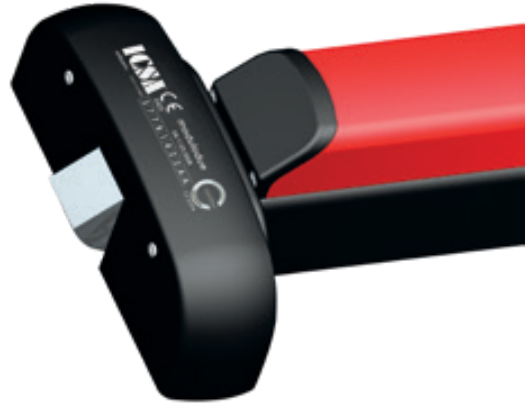

ART.
A601/.NR

COLOR
NEGRO / ROJO



1

ART.
A601/1..
A601/2..
A601/3..

LARGO
840
1170
1300

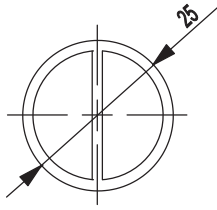

Adaptable para modelos:
A4/A5/A1/A10



COD.	L mm	
A1100/1/R	950	1
A1100/2/R	1.150	1
A1100/3/R	1.300	1

PINTADO ROJO - RAL 3020





CANDADOS

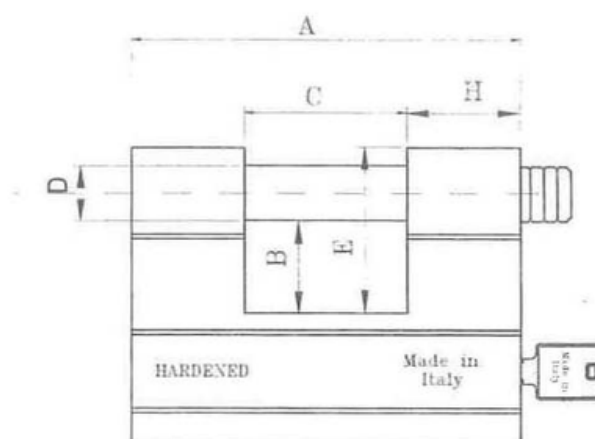
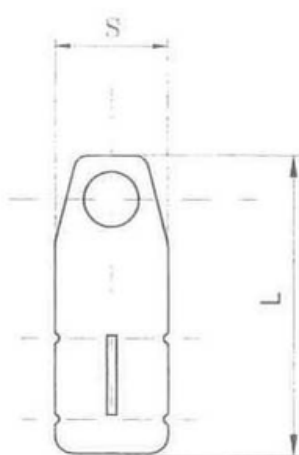

A mm	B mm	C mm	D mm	E mm	H mm	S mm	L mm
84	20	36	12	36	24	25	70

COD.
T4497/R



1



20

MOD APOLLO
CANDADO ARCO CORTO

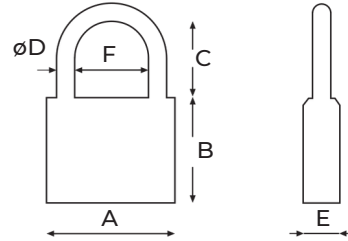

A mm	B mm	E mm	C mm	F mm	ØD mm	Kg	COD.
20	21	10,5	12	11,5	3,5	0,040	0901200000-
25	25	11,5	15	13,5	4	0,068	0901250000-
30	28	13	18	17	5	0,084	0901300000-
40	33	13,6	24	24	6	0,150	0901400000-
50	42	16,3	30	29	8	0,260	0901500000-
60	44	17,8	38	34	10	0,400	0901600000-
70	50	18,8	42	40	10	0,530	0901700000-

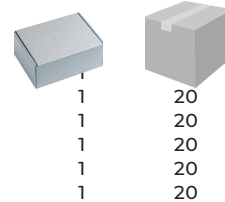

MOD APOLLO
CANDADO ARCO LARGO

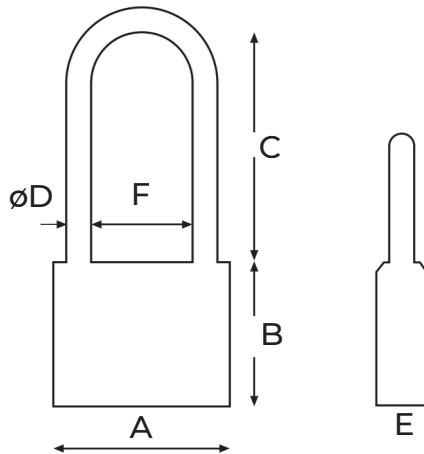

A mm	B mm	E mm	C mm	F mm	ØD mm	Kg	COD.
30	28	13	42	17	5	0,100	0902300000-
40	32	13,6	44	24	6	0,162	0902400000-
50	42	16,3	52	29	8	0,282	0902500000-
60	46	17,8	80	34	10	0,425	0902600000-

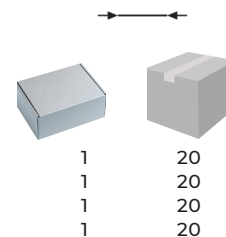

ICSA SERRATURE ESPAÑA

FABRICA DE CERRADURAS

SEBALCAB S.L.

CL/Leopoldo Alas N°8 - bajos

33204 - Gijón - Asturias

Tel. 985 053 052

icsa@sebalcab.es



WWW.ICSA.IT

PARA CUALQUIER NECESIDAD CONSULTE
EL CATÁLOGO GENERAL Y 23